Fannie Mae Strategic Plan
2007-2011

“Deepen Segments – Develop Breadth”



**PROPRIETARY AND CONFIDENTIAL -
CONFIDENTIAL TREATMENT REQUESTED
BY FANNIE MAE**

Confidential Treatment
Requested By Fannie Mae

FMSE 720693

Table of Contents

Introduction/ Executive Summary	Page 1
Section I Where We Are – Current Realities	Page 11
Section II Who We Are – Our Purpose, Mission, Vision	Page 17
Section III Where We Are Headed – Our Strategic Path	Page 19
Section IV How We Will Get There – Business Plans, Mission Impact	Page 41
Section V How We Will Measure Success – New Financial Measures and Metrics	Page 58
Section VI The Reintroduction of Fannie Mae – Writing the Next Chapter	Page 72
Summary and Conclusion	Page 78
Appendix: Where We Have Been – A Brief History	Page 80

**PROPRIETARY AND CONFIDENTIAL –
CONFIDENTIAL TREATMENT REQUESTED
BY FANNIE MAE**

**Confidential Treatment
Requested By Fannie Mae**

FMSE 720694

Introduction/Executive Summary

**Confidential Treatment
Requested By Fannie Mae**

FMSE 720695

Introduction

This Strategic Business Plan outlines the next chapter of the Fannie Mae story. This next chapter will be familiar in Fannie Mae's basic mission and business of bringing global capital to U.S. housing, but different in the company's tone, manner and approach to the market. That familiarity makes sense, given that we have reestablished a sound enterprise that serves a strong and growing market. The challenge now is to do more with our charter, mission, business and market opportunities – and in the end, put more families into housing affordably.

This Strategic Plan maps the course that Fannie Mae's management envisions taking the company over the next three to five years. Our strategy is built on several important conclusions:

1. We have a solid business and franchise – so we are writing a growth plan to **deepen our strongholds** in the guaranty and capital markets businesses while **extending the breadth** of the markets and instruments we touch.
2. We have opportunities to grow, in addition to pacing a growing market, by **emphasizing securitization and credit risk management**, and operating as One Fannie Mae. Following this strategy will result in solid earnings growth over the next five years.
3. For some time, our business has been perceived as being driven overwhelmingly by our portfolio business. We propose a **fundamental shift in terms of the economics** of the company. For the next five years, our guaranty businesses will produce more than 70 percent of our total net income while the portfolio will contribute 30 percent.
4. We are also proposing to the Board that we **enunciate some things we are NOT**: We are not a consumer company; we are not commencing a privatization plan; we are not defining mission as high risk/low return; and we are not unlike other corporations.

Together, these conclusions, which are discussed, analyzed and measured in this document, form the basis of a standard strategic plan. We thought, as we emerge from a few “non-standard” years, it would be important to undertake a comprehensive process, and to write it down. Two years ago, our plan was limited to the fundamental changes, critical investments and hard work the company needed to repair and rebuild the Enterprise on a stronger foundation. Our strategic planning process last year entailed a relatively targeted examination of new business initiatives as we focused our priority efforts on completing the restatement. This year our goal is bigger – to map out Fannie Mae's course for the next three to five years, leading up to 2012, our 75th birthday.

**PROPRIETARY AND CONFIDENTIAL –
CONFIDENTIAL TREATMENT REQUESTED
BY FANNIE MAE**

Confidential - Internal Distribution

1

**Confidential Treatment
Requested By Fannie Mae**

FMSE 720696

Executive Summary

At its core, we have a solid, successful franchise that earns billions of dollars a year by helping lenders put millions of working families into houses and apartments. Our business model – investing in and guaranteeing home mortgages – is a good one, so good that others want to “take us out.” We play a large role in our market, and since our market generally grows faster than the economy, we have room to grow. We do, sometimes, refer to Fannie Mae as a franchise, which reflects the complexities (or even contradictions) of running a for-profit business with a public mission, in the confines of a Congressional charter.

One of our key strategic challenges in growing value given a franchise like Fannie Mae’s is balance: of mission and business; of charter advantages and limitations; of competition and partnership. Our charter, while it imposes limits and obligations, also gives us unique and powerful competitive advantages. Our mission gives our work meaning and motivation. And the name Fannie Mae still carries significance to customers, partners, the market and communities.

That said, we do face tough new challenges – a weakening housing market; a slower-growing mortgage debt market; stiffer competition from new entrants and old customers; lender consolidation creating larger, stronger market players with more pricing power. Internally, while we have put the customer on top, we struggle to provide the service, products and solutions they need, when they need them. We are not as competitive as we need to be. Our systems are too complex and too lacking in flexibility. We have, therefore, a set of strategic challenges not unlike those faced by most large organizations; how to take the competitive advantages we have, apply them to the realities of the market, and obtain the best results for our owners and shareholders.

Starting with these realities, we have begun the next chapter of Fannie Mae’s history by formulating a new strategic plan. After months of research, analysis, discussion and preparation, our senior management team met for two days in June in a college classroom near Fannie Mae headquarters. We looked at where we’ve been and where we are now, as a company where we are headed, how we will get there, how we will measure success, and how we will reintroduce the company. We assigned teams to play devil’s advocate, or to write strategies for our competitors – to ensure we were looking at all sides of the problems. The debate was vigorous – and we made progress.

**PROPRIETARY AND CONFIDENTIAL –
CONFIDENTIAL TREATMENT REQUESTED
BY FANNIE MAE**

Confidential - Internal Distribution

2

**Confidential Treatment
Requested By Fannie Mae**

FMSE 720697

Where did we end up? After careful consideration, we made several major strategic decisions:

1. **Deepen and broaden businesses to maximize value.** We believe the charter provides ample opportunity for growth and expansion over the next three to five years. We can broaden – and deepen – our reach within the charter by pursuing both new business opportunities and greater penetration in the areas where we can offer and derive value. The seduction of losing current restrictions in trade for “a better deal” is becoming a distraction. Our strategic approach shifts from taking a two-dimensional view, the exhibit below, to a three-dimensional view of our opportunities within our charter, illustrated by what I call “Deepen Segments – Develop Breadth,” or less formally, the “3-D Egg,”¹ which we explain in Section III.

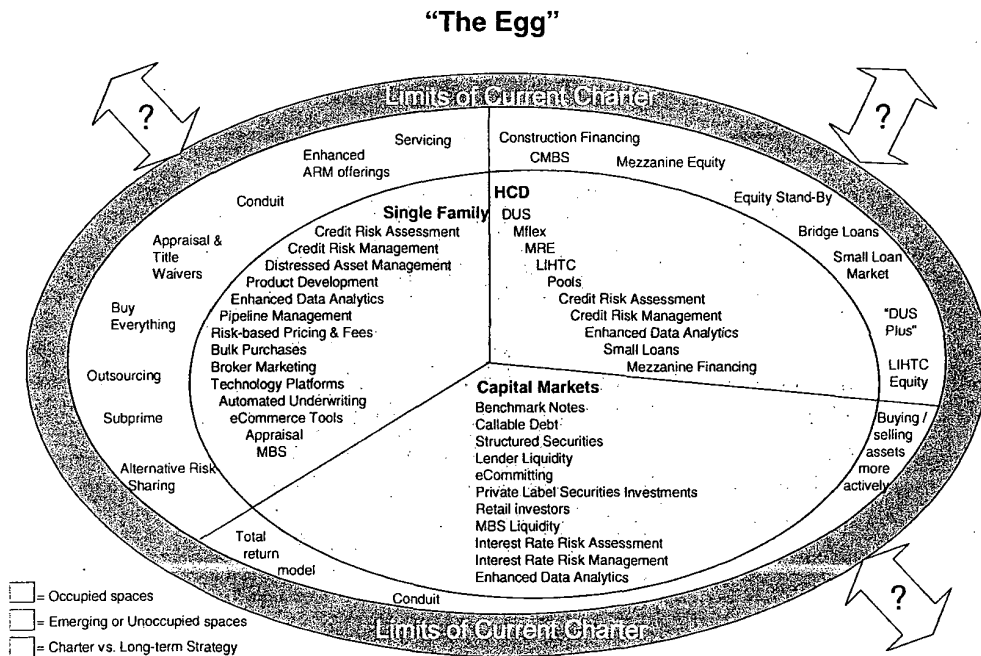

**PROPRIETARY AND CONFIDENTIAL –
CONFIDENTIAL TREATMENT REQUESTED
BY FANNIE MAE**

¹ “The Egg” was an idea from former Director Ann Korologos, who suggested we display the activities of the corporation, overlaid on the bounds of the Charter. The “3-D Egg” expands that notion to reflect the fact that not all activities have the same scale or value.

The "3-D Egg"

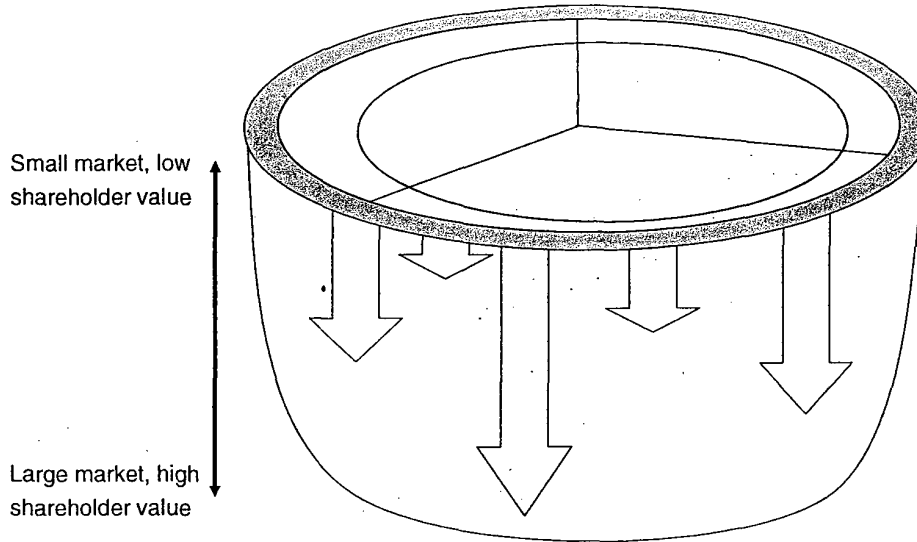

2. **Add more credit-sensitive assets.** Under our new strategy, we will take and manage more mortgage credit risk, moving deeper into the credit pool to serve a large and growing part of the mortgage market. A vast portion of this several hundred billion dollar market includes families who would make successful homeowners (or renters) and save money if we can draw them "into the egg." Helping reputable lenders serve emerging borrowers provides an enormous opportunity for Fannie Mae to grow, provide value to customers, the market and shareholders, and expand our affordable housing mission. In order to move deeper in the credit spectrum safely, however, we will need to complete the build-out of our new "Risk Transformation Facility" to give us the capability that our private-label competitors have to slice off and distribute credit risk into the market.
3. **Focus expansion on guaranty businesses.** As we manage more credit risk, our guaranty businesses – both Single-Family and Housing and Community Development – will offer our greatest growth potential, as well as opportunities to deliver on our affordable housing and liquidity missions, by moving deeper into the credit spectrum in the single- and multifamily mortgage assets we guarantee and securitize. *We expect these businesses to grow faster than the market, and provide double-digit net income growth.*
4. **Use Capital Markets capacity opportunistically.** Our Capital Markets business is central to our business strategy, as well as our mission and shareholder value. Having analyzed market valuation and risk management scenarios under a variety of assumptions, we do not believe the portfolio should be capped or reduced – but we do not expect growth rates as high as in the recent past. It provides liquidity and price support for our mortgage-backed securities; allows us to purchase mission-rich mortgage assets; and provides capital to the U.S. housing finance system when the market needs a stabilizing source of funds. The portfolio thus is "market dependent" – it will grow or shrink depending on what the market

**PROPRIETARY AND CONFIDENTIAL –
CONFIDENTIAL TREATMENT REQUESTED
BY FANNIE MAE**

Confidential - Internal Distribution

4

**Confidential Treatment
Requested By Fannie Mae**

FMSE 720699

needs and offers in price spreads. The scenario outlined in this plan assumes the portfolio grows from \$700 billion to \$800 billion and provides Fannie Mae with *single-digit income growth through 2011 with near double-digit adjusted rate of return on capital*.

5. **Mainstream our mission.** We need to advance our mission: the stability and liquidity of the secondary market, the financing of low- and moderate- and middle-income housing, and select “big-ticket” investments. Our mission cannot be limited to a nice-to-do or a one-off “boutique” operation. We deliver on our affordable housing mission every day through normal business, by purchasing or guaranteeing mortgage assets that serve low-, moderate- AND middle-class families; providing liquidity to underserved segments of the market; and, in doing so, bringing quality standards to those segments. Our plan to take more credit risk and broaden and deepen our reach – e.g., in the subprime market -- will bring more liquidity to affordable housing and to meet urgent housing needs. We have been somewhat defined by our critics, and have thus allowed our mission to become smaller and constraining.
6. **Regain competitiveness on cost and productivity.** Cost control and greater productivity are critical, doable and ongoing – since our business operates on a large scale, we can, and must drive growth without dollar-for-dollar expense growth. In fact, we have committed to reduce ongoing administrative expenses by \$200 million in 2007 and enter 2008 with a run rate of \$2 billion. Controls and critical skills come first – but each \$15 million in expense savings is worth a penny per share.
7. **Align financial disclosures with how businesses are managed.** We will demonstrate our financial performance by providing an expansive suite of transparent financials for our business segment results. These new measures and metrics will be aligned with how we manage the business: Single-Family and Housing & Community Development (HCD) results will be centered on GAAP net income; Capital Markets will be centered on adjusted fair value net income; and the total business by a composite measure called “Adjusted Net Income.” We explain this in detail in Section IV.
8. **Demonstrate shareholder value from organic growth.** Finally, and most importantly for our shareholders, we expect solid income and earnings growth from this strategy. As the chart on the next page shows, we project 13 percent compounded annual adjusted net income growth through 2011, from \$4.5 billion to \$7.3 billion, driven by revenue growth and cost containment; and over 14 percent compound annual adjusted earnings per share growth through 2011, from \$4.39 to \$7.49, driven by net income growth and stock repurchases. While certain sources of earnings volatility – spread, credit cycles, accounting impacts – are beyond management control, we think the overall shift toward guaranty fee income as a driver will be indicative of lower beta earnings.

PROPRIETARY AND CONFIDENTIAL –
CONFIDENTIAL TREATMENT REQUESTED
BY FANNIE MAE

Confidential - Internal Distribution

5

Confidential Treatment
Requested By Fannie Mae

FMSE 720700

\$B, unless noted	2007	2008	2009	2010	2011	07-11 CAGR
Adjusted Revenue						
Single Family	\$ 7.0	\$ 7.8	\$ 8.8	\$ 9.6	\$ 10.7	11.1%
Housing & Community Development	1.2	1.4	1.6	1.8	2.0	12.6%
Capital Markets	3.1	3.1	3.2	3.5	3.8	5.7%
Elimination	(0.8)	(0.9)	(1.0)	(1.0)	(1.0)	
Total Company	\$ 10.5	\$ 11.5	\$ 12.6	\$ 13.9	\$ 15.5	10.1%
Adjusted Net Income (1)						
Single Family	\$ 2.2	\$ 2.8	\$ 3.4	\$ 3.7	\$ 4.2	17.3%
Housing & Community Development	0.4	0.6	0.7	0.8	0.9	18.8%
Capital Markets	1.9	1.8	1.9	2.0	2.2	4.9%
Total Company	\$ 4.5	\$ 5.2	\$ 5.9	\$ 6.5	\$ 7.3	12.9%
Financial Metrics						
Adjusted EPS	\$ 4.39	\$ 5.18	\$ 6.01	\$ 6.66	\$ 7.49	14.3%
Quarterly Cash Dividends	\$ 0.47	\$ 0.55	\$ 0.73	\$ 0.81	\$ 0.93	18.2%
Share Repurchases (\$B)		\$1.0	\$0.4	\$0.6	\$1.1	
Adjusted ROE	12.2%	14.1%	15.5%	16.2%	17.2%	
GAAP ROE	12.6%	13.2%	13.9%	14.8%	15.2%	

(1) Excluding non-recurring admin expense / Catch-Up / Get Current and restructuring costs

With these decisions, taken together, how is our 2007-2011 strategic path different from our strategic course prior to the remediation period beginning in 2005?

- By realigning business segments, we will grow earnings on the less capital-intensive guaranty side.
- We will manage more credit risk both on-and-off balance sheet over time through a number of initiatives, including the expansion of our Risk Transformation Facility.
- Our approach to customers will be partnership, not oligopolistic or hostile.
- We will mainstream the mission with a “Big Tent” approach.
- Our financial numbers will be a scoreboard based on clear metrics and transparency.

Specifically, our Single-Family and HCD guaranty businesses likely will grow faster than the balance sheet, and the balance sheet will take on more credit-sensitive assets. Interest rate risk is likely to remain modest. This is a reversal from prior years, PROPRIETARY AND CONFIDENTIAL – CONFIDENTIAL TREATMENT REQUESTED BY FANNIE MAE

Confidential - Internal Distribution

6

Confidential Treatment
Requested By Fannie Mae

FMSE 720701

when adding high-grade MBS on the balance sheet and managing interest rate risk was a prime driver of earnings growth. As a result, by the end of 2011, securitization and credit will produce approximately 70 percent of our total net income, while investing in non-credit-sensitive assets on balance sheet will contribute 30 percent.

Under this plan, we project that our Single-Family and HCD businesses will increase net income from \$2.6 billion today to \$5.1 billion in 2011. This potentially would increase Fannie Mae's total market capitalization by nearly 85 percent, from \$65 billion currently to \$120 billion, as shown in the diagram below and detailed in Section V in our projected financial results.

Grow Shareholder Value Through Expansion and Shift in Business Mix

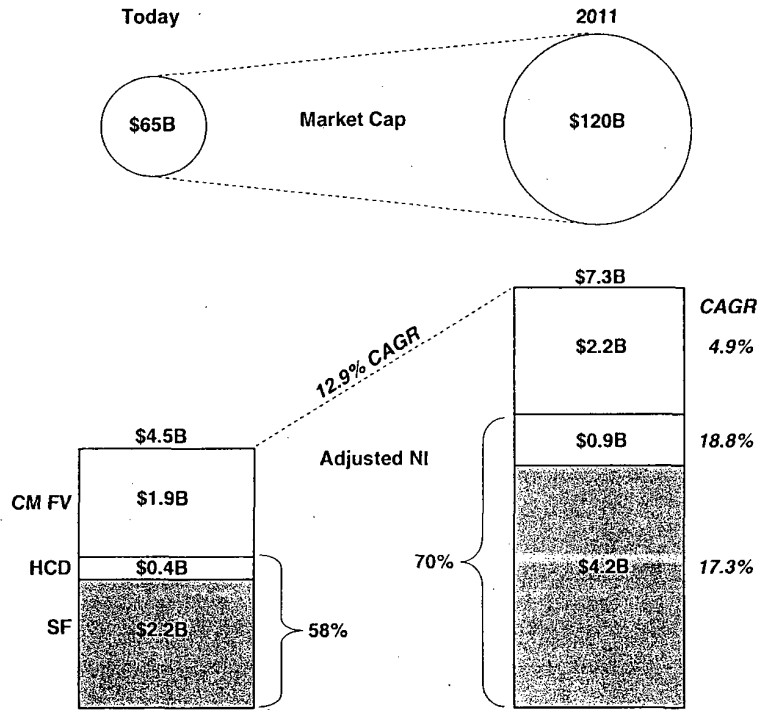

Our strategy will require some major changes at Fannie Mae. We need to be more competitive, entrepreneurial, market-driven, customer-focused, efficient and productive as a company – we need to eliminate the remaining vestiges of bureaucracy. More specifically, we need to take a more business-like, analytical approach to risk, especially credit risk. This is paradoxical. For a company that specializes in managing mortgage risk, gets paid to manage mortgage risk, knows more about mortgage risk because we simply have more data to mine, and is very good at it, we're still remarkably risk-averse. Our total credit losses over the past ten years were \$3.1 billion versus net income of \$44.2 billion, with 25 percent of those losses in 2006. The average loss ratio for residential loans made by banks is five times Fannie Mae's

**PROPRIETARY AND CONFIDENTIAL –
CONFIDENTIAL TREATMENT REQUESTED
BY FANNIE MAE**

Confidential - Internal Distribution

7

Confidential Treatment
Requested By Fannie Mae

FMSE 720702

average; for non-residential loans, the bank average is upwards of 35 times Fannie Mae's average.

Our competitors – especially commercial banks, Wall Street firms and hedge funds – have developed footholds – but also suffered major failures – in expanding credit segments. With our competitive advantages, our mission quest, our high standards, our knowledge of mortgages and our talent, Fannie Mae can help lenders extend mortgage credit to more families, the right way, at lower cost.

* * *

Planning process step by step. This plan is the result of a strategic planning process that began in 2005, when we envisioned moving the company forward in three overlapping phases.

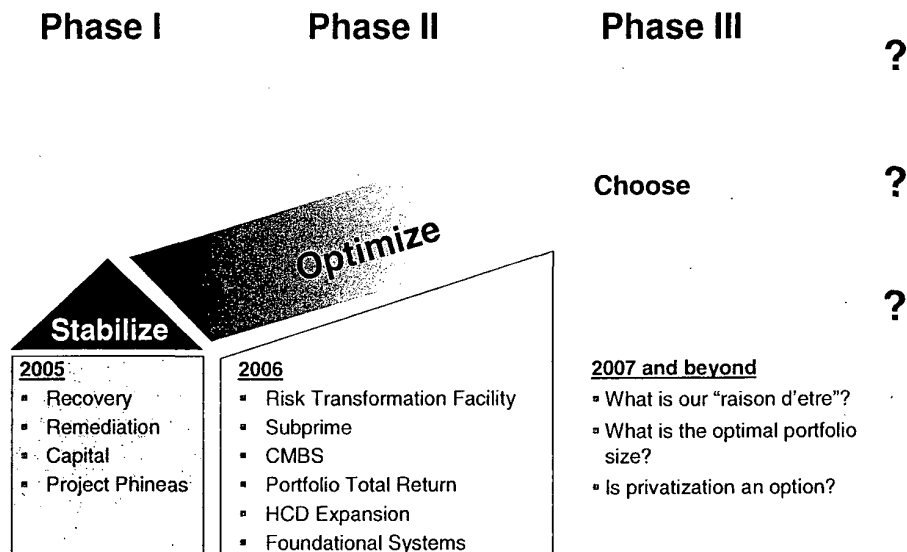

Phase I was to "Stabilize" the company by completing the remediation and restatement and becoming a current filer, and resolving legal and regulatory "overhangs."

Phase II was to "Optimize" our business model by exploring new opportunities within our charter, which resulted in the organizational changes and the new initiatives of 2006.

We have now begun Phase III, called "Choose." Now that we are close to operating normally, we have the basics to think more broadly about our future, and make long-term choices about our businesses, our markets, our customers and our capacity to increase shareholder value.

**PROPRIETARY AND CONFIDENTIAL –
CONFIDENTIAL TREATMENT REQUESTED
BY FANNIE MAE**

Confidential - Internal Distribution

8

**Confidential Treatment
Requested By Fannie Mae**

FMSE 720703

Our strategic planning process looks like several “trains” coming together, as shown in this diagram:

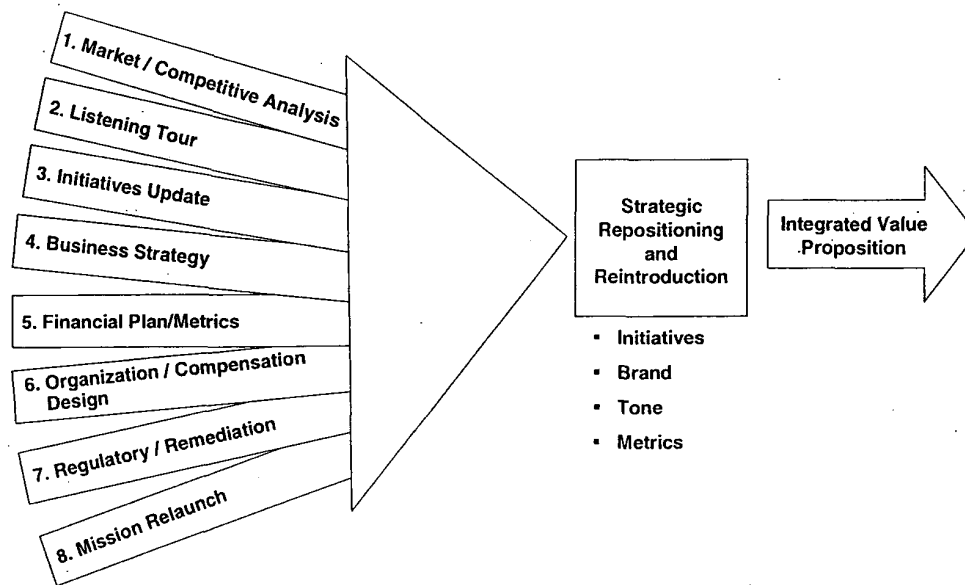

We examined our market and competitive environment; factored in what we heard from our “listening tour” with customers and partners; reviewed the new business initiatives we launched in 2006; and from there, developed a business strategy, a financial plan and the metrics to show our performance. From these “trains,” we developed our strategic path, considered how to reintroduce the company with new initiatives, “brand,” tone and metrics, and worked to produce an integrated value proposition.

Pursuant to our one-on-one meetings with Directors, we also addressed a number of important, foundational questions:

- Is privatization an option?
- What is the optimal portfolio size?
- What is our *raison d’etre*?

The answers to these questions enabled us to answer broader questions of value add, relevance increase, and capital allocation.

In this plan, we assess those questions and propose answers, forming the basis for our strategy. In turn, our strategy is the key pillar in the upcoming reintroduction of Fannie Mae as we complete this chapter of our company’s history – and write the next.

**PROPRIETARY AND CONFIDENTIAL –
CONFIDENTIAL TREATMENT REQUESTED
BY FANNIE MAE**

Confidential - Internal Distribution

9

**Confidential Treatment
Requested By Fannie Mae**

FMSE 720704

Summary of Introduction and Executive Summary:

- *Deepen and broaden businesses to add value – leverage charter capabilities.*
- *Add credit-sensitive assets.*
- *Expand guaranty businesses – look for capital markets opportunities.*
- *Mainstream the mission.*
- *Regain competitiveness on cost and productivity.*
- *Measure, disclose and explain metrics to increase value.*

Process Drives Plan, Execution, Business Results

**PROPRIETARY AND CONFIDENTIAL –
CONFIDENTIAL TREATMENT REQUESTED
BY FANNIE MAE**

Confidential - Internal Distribution

10

**Confidential Treatment
Requested By Fannie Mae**

FMSE 720705

**Where We Are –
Current Realities**

**Confidential Treatment
Requested By Fannie Mae**

FMSE 720706

Section I: Where We Are – Current Realities

- *Recovery is proceeding, but more to do.*
- *Making progress on 2007 objectives, including optimizing business.*
- *We are ready to choose our strategic path for next 3-5 years.*

We began our 2007 strategic planning process by taking stock of our current realities, looking at several key indicators:

- 1) Progress on our corporate priorities for 2007;
- 2) Analysis of what our customers, partners, employees are telling us;
- 3) What our shareholders are telling us through our stock price, and a detailed valuation analysis;
- 4) Our regulatory and legislative status; and
- 5) Status of the strategic business initiatives we launched in 2006.

1. Priorities for 2007: The corporate priorities for the year reflect the remediation work that remains to be completed, as well as business opportunities that lay fallow or untapped and the improvements to our foundation (e.g., systems, culture) needed to become a more market-driven, competitive company. The priorities are: 1) Grow revenues, reduce costs, exceed mission; 2) Operate in real time, including modernizing our technology infrastructure, and launching Lean Six Sigma operational efficiencies across the company; 3) Clean up, including completing our financial filings for 2005 and 2006, and then, filing our 2007 results; and 4) Accelerate culture change, with a strong emphasis on people management and instilling a greater sense of enterprise and competitiveness in the market. At mid-year, we are on track to achieve most of our 2007 corporate objectives, although we are deep in the hole on the HUD goals. The table below shows where we are as of May against the target for each objective:

Corporate Objectives	YTD Results vs. Minimum Targets
SF Book Growth	165% vs. 90%
SF Return	86% vs. 70%
MF Book Growth	14.8% vs. 2.5%
MF Charged Fees	24.8 bps vs. 21.8 bps
HCD New Initiatives	\$325MM vs. \$298MM
Total Return on Portfolio	619 bps vs. 400 bps over LIBOR
Administrative Expenses	\$1,138MM vs. \$1,207MM YTD
HUD Goals	Several well below plan
Minority Lending Goals	On plan

All options to achieve the HUD goals are being evaluated and considered. In the event we reach a viewpoint that achieving the goals this year is “infeasible,” we will determine how best to address the matter with HUD and will continue to keep the Board apprised accordingly.

**PROPRIETARY AND CONFIDENTIAL –
CONFIDENTIAL TREATMENT REQUESTED
BY FANNIE MAE**

Confidential - Internal Distribution

11

**Confidential Treatment
Requested By Fannie Mae**

FMSE 720707

Management will formally report to the Board at year end on progress toward these objectives. In the meantime, as noted previously, we've made measurable progress in completing our financial filings by accelerating our previous timeline. We also are getting close to reducing our 2007 expense run rate by an additional \$200 million, toward our target exit annual run rate of \$2 billion.

2. Listening tour feedback: Prior to our strategic planning retreat in mid-June, I directed the senior management team to conduct a systematic "listening tour" with customers, housing partners, investors, employees and other stakeholders. The group conducted close to 300 interviews/engagements with internal and external customers, including large, small, and mid-sized lenders, investors, partners and officials. Their feedback was useful background for our strategic work; in summary:

- Business partners continue to view Fannie Mae as a leader in housing and housing policy; they would like us to **behave more like a leader**. That means pioneering new technology; speaking to industry issues; initiating solutions with customers; driving new product development; and helping to resolve the sub-prime and future market crises.
- The company's tone and manner has changed noticeably. During the last company-wide listening tour in January 2005, three comments we heard most often were: lose the culture of arrogance (cultivate a new tone and manner in dealing with partners); develop a stronger working relationship with OFHEO; and be more creative and open to different approaches. Two years later, **partners broadly acknowledge improvements** in tone; several note a dramatic move toward more respectful/less dismissive interaction.
- However, some say that while we've lost the arrogance and we listen, we don't always act, suggesting a corporate culture of the "**slow maybe**" (or maybe even "slow no"). Fannie Mae would better address customer concerns if we were more candid and upfront; where we can't say "yes," giving a clear "no" – or at a *minimum*, timeframes for getting back to our partners with a decision. On some specific issues partners found us responsive to requests to innovate, take new approaches, and take risks; they cited MyCommunityMortgage and the Low-Income Housing Tax Credit (LIHTC) sale.
- Partners said we need to do a better job of identifying **single points of contact** here so they do not have to "surf" Fannie Mae and ask multiple points of contact to find an answer.
- Employees echoed the "change, progress, more to do" messages that the management team and I have shared through various internal communications (intranet, town hall meetings, company-wide and targeted email), which suggests a **good level of engagement**.
- We also heard a great deal of concern, even **anxiety, about the cost-cutting**, productivity and restructuring efforts – especially the impact on benefits. (I was

**PROPRIETARY AND CONFIDENTIAL –
CONFIDENTIAL TREATMENT REQUESTED
BY FANNIE MAE**

Confidential - Internal Distribution

12

**Confidential Treatment
Requested By Fannie Mae**

FMSE 720708

surprised at the reaction to our reexamination of the ACE college aid program). Some housing partners and former Foundation beneficiaries also expressed concern about cutbacks.

Our takeaway from the customer feedback, then, is essentially: good progress on tone and partner-like attitude; not happy with bureaucracy and unresponsive timing.

3. Customer positioning – Single-Family, HCD, Capital Markets

The turmoil in the subprime market has increased demand for Fannie Mae's securitization business over our private-label competitors as the mortgage market moves from "exotic," layered-risk loans to more traditional fixed- and adjustable-rate mortgages. At the same time, major lenders – both single-family and multifamily, including our longstanding customers – have more options, including their own mortgage portfolio and securitization operations, Freddie Mac's more aggressive pricing for market share, and a continued flood of cheap capital in the multifamily market. So we have had to be more aggressive as well. Here is a snapshot:

- Single-Family: Wells Fargo, the second-largest mortgage originator, has increased the share of its origination business coming to us for securitization, from 20 percent to 50 percent. We also signed agreements with JP Morgan Chase and National City to sell us a majority of the loans they originate; previously they sold a majority to Freddie Mac. Net-net, we've won customers that had to have a strong value proposition beyond price compared with competitors. However, Freddie Mac has made inroads with our number-one customer, Countrywide, boosting its share of the lender's business from about 10 percent to about 30 percent. The biggest challenge we face is whether large financial institutions with mortgage lending operations and maturing private-label securitization operations and mortgage portfolios with sophisticated hedging strategies build their own "Fannie Mae." Our response is to strive for "best execution" in price and in service.
- Multifamily: Stiff competition from conduits making debt investments in rental housing (e.g., buying bonds to finance apartment developments) has lowered the profit margins for this segment for the foreseeable future. HCD, which operates our multifamily lending business, is moving to increase volume by being more responsive to our close network of multifamily lender customers – "Delegated Underwriting and Servicing," or DUS lenders. For example, we are streamlining our DUS underwriting platform through "lean" process redesign and product innovation, and creating integrated teams to provide rapid, flexible response to customer needs. Also, we are expanding our source of multifamily investments beyond our DUS lenders to include investment banks, regional small multifamily lenders, intermediaries, equity funds and other commercial real estate investment partners.
- Capital Markets: The mortgage portfolio team works closely with Single-Family and HCD to support the competitiveness of their pricing in the market and liquidity of our MBS. They support our purchase of multifamily loans and our multifamily MBS executions; we need to ensure the portfolio can continue to support these MBS. We are also exploring new securitization structures and financial instruments to lay off risk, including

**PROPRIETARY AND CONFIDENTIAL –
CONFIDENTIAL TREATMENT REQUESTED
BY FANNIE MAE**

Confidential - Internal Distribution

13

**Confidential Treatment
Requested By Fannie Mae**

FMSE 720709

Collateralized Debt Obligations, and Credit Default Swaps. Our relations in the broker-deal community remain a strong point.

4. Shareholder value: Fannie Mae's common stock price has recovered over the past two years, notably in 2007.

Year-To-Date Stock Performance

	12/31/2006	6/27/2007	% Change
Fannie Mae	\$59.39	\$66.18	11.43%
Freddie Mac	\$67.90	\$61.22	-9.84%
S&P 500	1,418	1,496	5.45%
S&P Financials	495	485	-2.12%

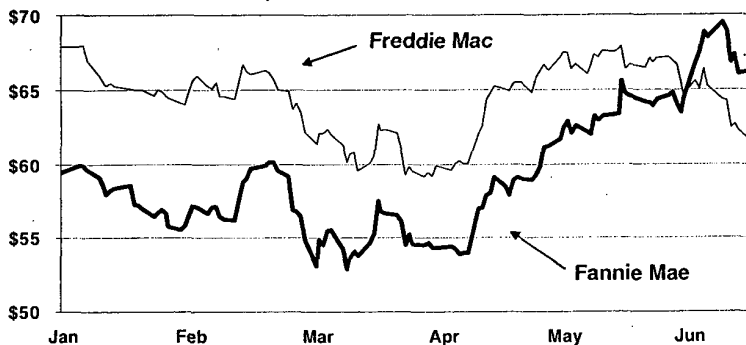

Starting the year just below \$60 per share, on June 18 the price reached nearly \$70, a 17 percent increase and three-year high. In comparison, the S&P 500 was up nearly eight percent, the S&P financials were up almost two percent, and Freddie Mac's stock price was down over five percent. Indeed, for the first time since December 2004, Fannie Mae's stock price surpassed Freddie Mac's. Sell-side analysts have expressed significant interest; several upgraded their price targets and guidance for reasons including our accelerated filing schedule, prospects for our guaranty business, new subprime opportunities, strong 2005 disclosures and business segment reporting, and, capital return. We have held over 100 investor meetings in 2007 – the summary is short and sweet: They want current numbers, clear metrics and a clear explanation of the business model.

5. Regulation/remediation/legislation: Fannie Mae has made progress in these areas. OFHEO continues to hold the company under tight scrutiny as we comply with and/or complete the terms of our consent agreements and our remediation efforts (accounting, controls and systems). But while some disagreements occasionally arise, our efforts to build a more normal, cooperative relationship have allowed us to work through some issues. I personally conducted a listening visit with Director Lockhart, who at the time expressed satisfaction with the state of the relationship. As for HUD, we believe that we met our affordable housing goals and subgoals for 2006, but the agency will make the final determination later this year. Meeting HUD's housing goals and subgoals continues to be challenging, particularly as the

**PROPRIETARY AND CONFIDENTIAL –
CONFIDENTIAL TREATMENT REQUESTED
BY FANNIE MAE**

Confidential - Internal Distribution

14

Confidential Treatment
Requested By Fannie Mae

FMSE 720710

mandated levels for goals and subgoals continue to increase annually and declines in housing affordability during the past several years have reduced the share of available loans meeting the goals. Our remediation continues apace as we issued our 2005 financial statements in May and announced in June that we expect to file our 2006 financials during the third quarter of this year, and become a current filer by the end of next February by filing our 2007 financials. On legislation, the House of Representatives passed a GSE regulatory reform bill with an amendment easing potentially harsh portfolio restrictions, but Senate action has stalled and does not appear likely this year. The summary here is, essentially, we are not yet in position to get the benefit of the doubt, so we have to stay absolutely consistent.

6. Progress on initiatives: In 2006, we identified and selected specific initiatives to pursue as a result of the optimization phase of our strategy and presented the results to the Board of Directors for review. Those initiatives were the result of our considering different potential scenarios and possible futures for the company. We decided at the time to stay the course and work within our charter with the current business model, rather than choose a “long ball” strategy. The selected strategy – dubbed “The Egg” – depicts a circle (the current reach of our business) within a larger oval (the extent of our charter), showing we have significant untapped market opportunities to explore within our charter. After considering the relevant risks and returns of several options, management decided on several strategic initiatives that have, in fact, delivered sizeable dollars, as the table below depicts:

Acquisition Volume from Business Initiatives

Initiative	2004 actual (\$ billion)	2007 forecast (\$ billion)	2011 forecast (\$ billion)
Subprime	\$0	\$11.3	\$26.4
Alt-A	\$39.9	\$114.4	\$150.4
2nds	<\$0.1	\$4.0	*
Reverse Mortgages	\$3.5	\$6.2	\$6.2
Small MF Loans	n/a	\$2.2	\$5.0
For-Sale/Rent Equity	\$0.3	\$0.6	\$1.0
Community Lending (incl. AD&C)	\$0.5	\$1.4	\$4.3
Mezzanine Financing	<\$0.1	\$0.1	\$0.4
CMBS	\$0	\$25	\$95
<AAA Securities	\$0	\$1	\$5

* Not separately planned in the forecast

Overall, as you know, the recovery of Fannie Mae is proceeding apace. We are near completion on Stabilization and have generated measurable value from Optimization. On the “good” side of the ledger, the company is committed to doing more for customers and partners, and growing as the market grows; doing more for affordable housing; doing more for investors and shareholders; doing more with our people; and doing more to ensure that Fannie Mae operates as a 21st Century financial institution (e.g., competitiveness, speed, agility,

**PROPRIETARY AND CONFIDENTIAL –
CONFIDENTIAL TREATMENT REQUESTED
BY FANNIE MAE** 15

Confidential - Internal Distribution

**Confidential Treatment
Requested By Fannie Mae**

FMSE 720711

efficiency). On the “bad” side of the ledger, the company has ongoing systems remediation; regulatory limitations; lack of clear definition; credit losses on the upswing; the lack of a market-competitive culture; strains to work, life, morale and our plant; and a continual stretch to reach our HUD goals.

Summary of Section I: Current Realities

- *Substantial progress on 2007 objectives*
- *External relations improving*
- *Share price recovering*
- *Systems remediation ongoing*
- *Market environment tougher*
- *Culture – ongoing challenge*

**PROPRIETARY AND CONFIDENTIAL –
CONFIDENTIAL TREATMENT REQUESTED
BY FANNIE MAE**

Confidential - Internal Distribution

16

**Confidential Treatment
Requested By Fannie Mae**

FMSE 720712

**Who We Are -
Our Purpose, Mission, Vision**

**Confidential Treatment
Requested By Fannie Mae**

FMSE 720713

Section II: Who We Are – Our Purpose, Mission, Vision

- *Our purpose and mission is still reflected in “Our Promise.”*
- *Our vision going forward: We reach globally and act locally; we are a valued partner; our business = our mission; we are a company where people can be proud to work; and we bring measurable value to customers, partners, the market and housing.*

After taking stock of our current realities, our strategic planning process then examined our purpose and mission as a company, and from that, we set forth our vision. The following section discusses how we addressed these questions.

Purpose, Mission, Vision

Towards the end of 2005, the Executive Committee worked through and agreed upon a document called “Our Promise.” In it we outlined the company’s purpose and mission going forward as the basis for the culture we wanted to create, and the construct remains relevant.

Our Purpose: *We exist to expand affordable housing, to bring global capital to local communities, and to exemplify high standards for the U.S. secondary mortgage market.*

Our Mission: *Shareholders own the company – our obligation is to maximize long-term shareholder value. Customers and investors rely on us – our business depends on them. Communities are why we exist – our mission is to serve them. Employees make it happen – our commitment is to work together to make a difference for all our constituencies: shareholders, customers, investors, and communities.*

From this purpose and mission, I drafted a statement called “Our Vision for One Fannie Mae,” intended to capture the company’s intentions and aspirations, and guide the strategic options we consider and choose. I circulated the idea to the senior management team at our June strategic offsite meeting, and we made changes and refinements to reflect the group’s views. Currently, the vision statement reads as follows:

Our Vision for One Fannie Mae

Reach globally, serve locally: *Fannie Mae brings global capital to local communities to finance affordable housing. The Fannie Mae Mortgage Backed Security is the leader in the market – the most liquid, the best execution, the preferred collateral in the debt market. We are a AAA issuer. We earn solid, reliable investment returns via broad understanding of markets. We operate large scale, but we respond nimbly and decisively to seize opportunities.*

Valued partner: *Fannie Mae is critical to U.S. housing finance. Mortgages are what we do, our core competence. Quality lenders want our partnership and products, and consumers benefit from what we do. Activists, advocates and policymakers value our role and experience. What we do matters to people in housing finance. Where we partner, we –*

**PROPRIETARY AND CONFIDENTIAL –
CONFIDENTIAL TREATMENT REQUESTED
BY FANNIE MAE**

Confidential - Internal Distribution

17

**Confidential Treatment
Requested By Fannie Mae**

FMSE 720714

and our partners – win. Where we compete, we play hard but fair. By bringing our high standards to the market, we make it hard for bad actors to win.

Business = mission: *Fannie Mae is a growing, competitive business on a mission. We focus on a double bottom line: Business and Mission results both matter. We earn double-digit ROE; we grow above the market. We produce a competitive yield among financials. We actively manage capital: invest it when returns are good; return it to shareholders otherwise. Likewise, we may keep risk, sell it, or avoid it, depending on our view. We are more productive every year. Key processes operate at Six Sigma. We are urgent, committed, and forward-looking. Our mortgages are the “fairest of them all” – you get lower cost and better access with a Fannie Mae mortgage. We are known for delivering results, not for hype.*

Proud to work here: *Fannie Mae strives to be a model workplace and corporate citizen. We provide opportunities to work with talented, diverse people and make a difference. Employees own their future here, both success and failure. Our company is known for openness, honesty and transparency. We are not “special” or above the rules. We operate as a normal company.*

Measurable value: *The numbers – not assertions – demonstrate our vision in action. Our share price reflects the results of all three business segments. Our share price can reach \$120 as illustrated later in Section V. Our mission results can be counted beyond the HUD goals. Our cost, productivity and returns can be measured. Our accounting can be reconciled to our economics. The numbers add up to value creation.*

Together, the statement of Purpose, Mission and Vision provided management with a common basis to select – or reject – specific strategies.

**PROPRIETARY AND CONFIDENTIAL –
CONFIDENTIAL TREATMENT REQUESTED
BY FANNIE MAE**

Confidential - Internal Distribution

18

**Confidential Treatment
Requested By Fannie Mae**

FMSE 720715

Where We're Headed -
Our Strategic Path

**Confidential Treatment
Requested By Fannie Mae**

FMSE 720716

Section III: Where We Are Headed – 2007-2011 Plan

- *We looked at the environment around us –the housing market is turbulent and our market is more competitive.*
- *We answered three Board strategic questions: 1) Privatization is not a good option right now; 2) the portfolio is crucial to our mission and business and should not be reduced to an arbitrary target level; and 3) our primary raison d'etre – where our business can center its activities – is in securitization and credit risk management.*
- *We chose a strategic path – to broaden and deepen our reach within our charter.*
- *This path will lead us to more credit sensitive activities.*

The next step in our planning process was to choose a strategic path. After taking stock of where we are, and our vision of who we want to be, we then made some key assumptions, based on an analysis of the our external environment and the answers to three internal questions: 1) Is privatization an option? 2) Should we maintain, grow or reduce the portfolio? and 3) What is our *raison d'etre* – the best purpose on which we should focus our business? This section describes our view of the market and competitive environment, addresses the three “big questions,” and then describes the strategic path we recommend.”

Global trends, industry/competitive environment

Over the next three to five years, we believe that the housing and mortgage markets will regain traction and begin the next multiyear upturn. The negative trends of the past several years will work themselves out over the next year or so (meaning that the bottom hasn't been reached quite yet), and the positive underlying economic and demographic forces will reassert themselves over the second half of the strategic plan period. Structural changes in the competitive landscape, however, will continue and are likely to pose substantial challenges for Fannie Mae.

- **Unsustainable Trends:** Two primary forces boosted housing and mortgage market activities to unsustainable levels in recent years: excess liquidity and investor demand for housing. A combination of cheap credit (driven by Fed easing through mid-2004 in response to deflation fears) and a surge in foreign investment in U.S. financial assets (the flip side of the rising trade deficit) created an unprecedented flood of liquidity that helped to spur record demand for housing and mortgage assets.

**PROPRIETARY AND CONFIDENTIAL –
CONFIDENTIAL TREATMENT REQUESTED
BY FANNIE MAE**

Confidential - Internal Distribution

19

**Confidential Treatment
Requested By Fannie Mae**

FMSE 720717

Excess Liquidity Before Less Liquidity Now

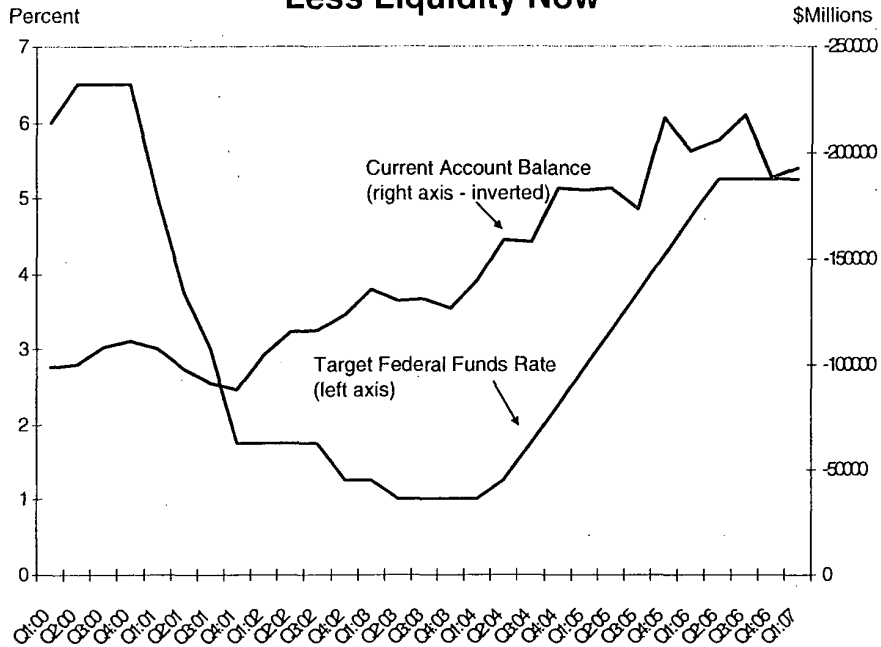

Source: Federal Reserve Board, Bureau of Economic Analysis

Investor Share Slipping From Record Highs

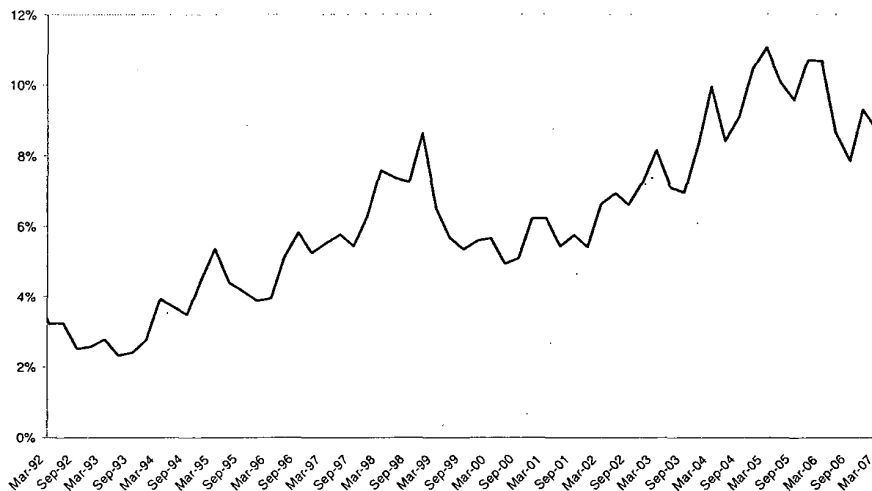

Note: Shares are based upon number of Prime Conventional Conforming Purchase loans
Source: LoanPerformance March 2007 data

**PROPRIETARY AND CONFIDENTIAL -
CONFIDENTIAL TREATMENT REQUESTED
BY FANNIE MAE**

Confidential - Internal Distribution

20

**Confidential Treatment
Requested By Fannie Mae**

FMSE 720718

- **Near-term trends:** Rising interest rates and tightening lending standards are finally putting the squeeze on liquidity. We expect that strong foreign demand for mortgage assets will moderate only slightly, but a larger pull-out is a risk.

Total Home Sales

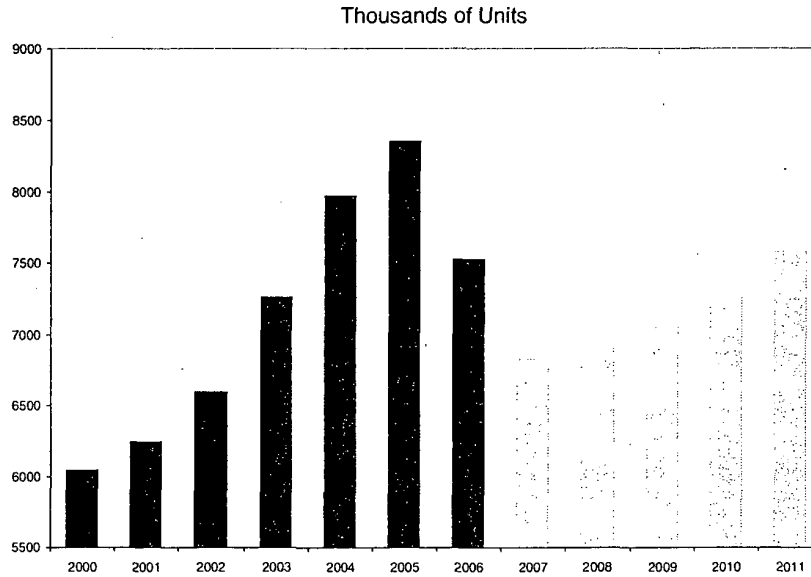

Source: Bureau of the Census, National Association of REALTORS®, Fannie Mae forecast

Fannie Mae House Price Index and Inventory of Unsold Homes

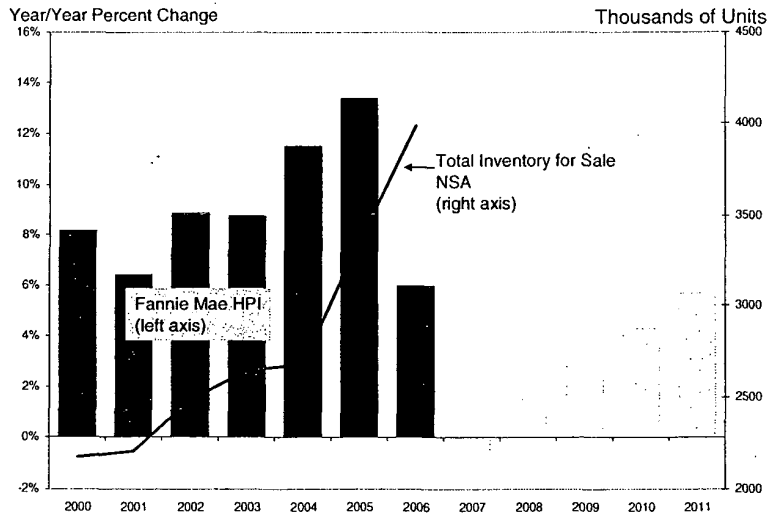

Source: Bureau of the Census, National Association of REALTORS®, Fannie Mae

**PROPRIETARY AND CONFIDENTIAL -
CONFIDENTIAL TREATMENT REQUESTED
BY FANNIE MAE**

Confidential - Internal Distribution

21

**Confidential Treatment
Requested By Fannie Mae**

FMSE 720719

Moreover, investor demand for housing is slackening, as double-digit house price gains are long gone. As a result, the decline in housing and mortgage market activity has not yet run its course. Total home sales will be down by nearly another 10 percent this year. Near-record unsold inventories continue to push house prices downward, and we project national declines this year and perhaps in 2008 as well. This combination of slower sales and lower house prices will pull purchase originations down by more than 12 percent this year. With fewer home sales, a slowing in refinance activity (in response to higher mortgage rates), and less mortgage equity withdrawal, mortgage debt outstanding (MDO) growth should slow sharply to approximately 6 percent this year.

The Housing Market Has Shifted Significantly

Indicators	2005	Q1 2007
Home prices peaked ¹	+15.3%	-2.9%
Home sales declined	8.36M units	7.28M units
Rental vacancy rate stable	9.8%	10.1%
Subprime industry meltdown ²	22%	14%
Credit losses increased ³	10.8%	13.3%
ARM share of market declined ⁴	31.4%	21.0%
Private label securities market peaked ⁵	54.8%	9.7%

1. Case-Shiller home price index; Q1 2007 figure is an annualized rate
2. Subprime share of single-family market originations
3. Conventional subprime loans past due
4. MBA ARM share of mortgage applications
5. Growth in private label mortgage-backed securities

- **Long-term positives:** Most analysts expect the overall economy and job market to rebound modestly next year, with growth at around trend rates beyond that – which will add to housing demand. Once investors end their retreat from the housing market, and job growth rebounds, home sales should begin to grow again (albeit modestly) – probably by early 2008. Beyond that, demographic trends suggest that home sales should climb at around a 3-4 percent pace annually from 2009-2011. While we still expect some house price weakness in 2008, house prices should rise in 2009 and continue to grow through 2011 – back to the long-term trend of around 4 percent. MDO growth is projected to be a modest 5-6 percent over 2007-2011, as it was in the 1990-95 period, although growth should accelerate in the latter years of the plan as home price gains and home sales increase.

**PROPRIETARY AND CONFIDENTIAL –
CONFIDENTIAL TREATMENT REQUESTED
BY FANNIE MAE**

Confidential - Internal Distribution

22

**Confidential Treatment
Requested By Fannie Mae**

FMSE 720720

Mortgage Originations vs. Single-Family Mortgage Debt Outstanding

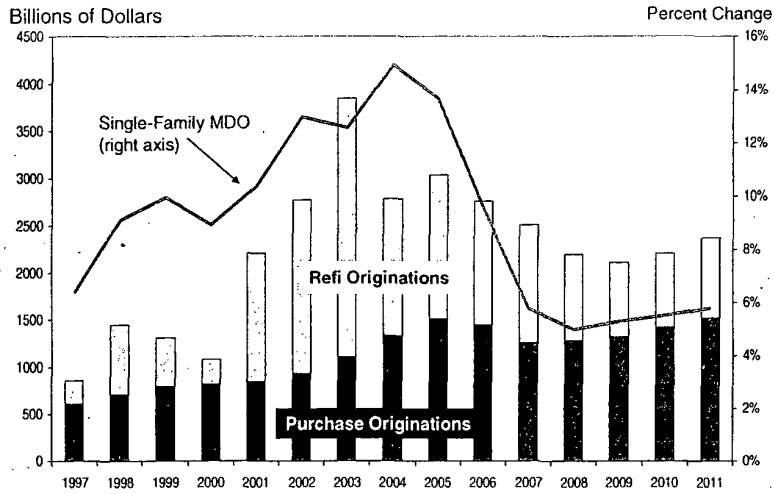

Source: Fannie Mae estimates, Federal Reserve Board

- Competitive challenges:** The continuation of consolidation and disintermediation in the U.S. mortgage finance value chain remain significant challenges to Fannie Mae's business trajectory.

Top 10 Lender Share of Market

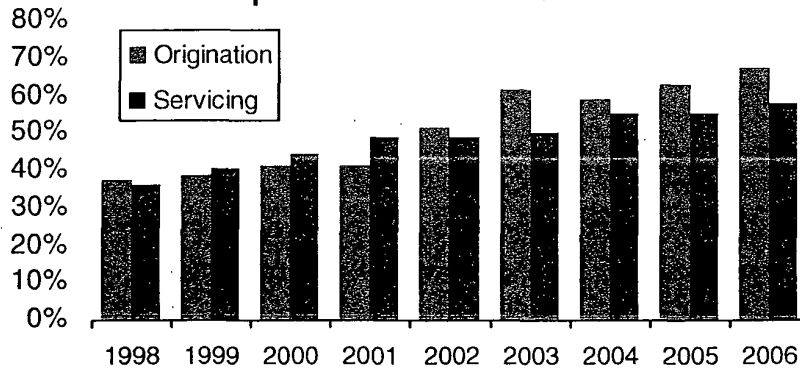

Source: Inside Mortgage Finance

Market slowdowns tend to spur consolidations. Each round of industry consolidation during the past 10 years has created larger and stronger market players with increasing pricing power relative to the GSEs. The largest players are driving decreasing profit margins in the industry, and margin pressure will likely continue as the large firms squeeze costs across the housing finance industry.

Private label securitizations rose sharply in the 2004 to 2006 period along with the expansion of new products for investing and managing mortgage credit risks. In

**PROPRIETARY AND CONFIDENTIAL -
CONFIDENTIAL TREATMENT REQUESTED
BY FANNIE MAE**

Confidential - Internal Distribution

23

**Confidential Treatment
Requested By Fannie Mae**

FMSE 720721

addition, large banks and aggregators expanded their capital markets capabilities to provide alternatives to Wall Street and the GSEs, eating into our market share.

Fannie Mae Reclaiming Market Share

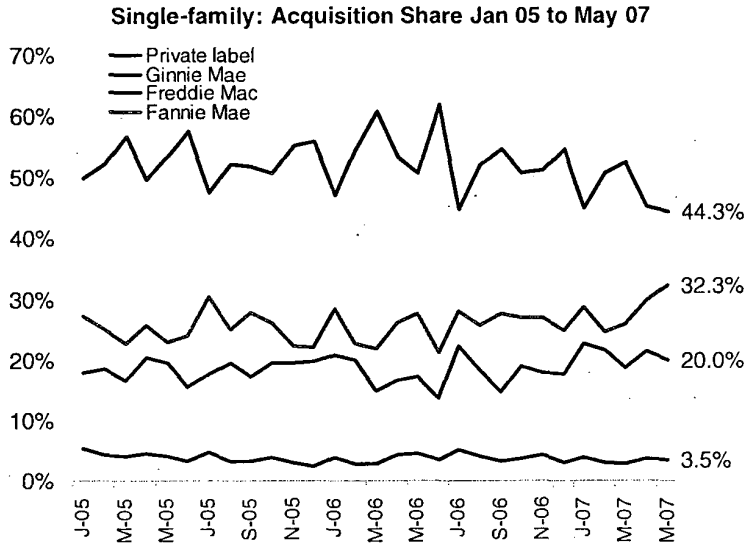

Source: Bond Buyer, Inside MBS & ABS, Company reports

At the same time, new and existing investors in the mortgage space have a greatly expanded menu of tools to invest in and hedge mortgage-related risks (e.g. credit default swaps, collateralized debt obligations, credit-linked notes, and covered bonds).

Credit Derivatives Outstanding (notional)

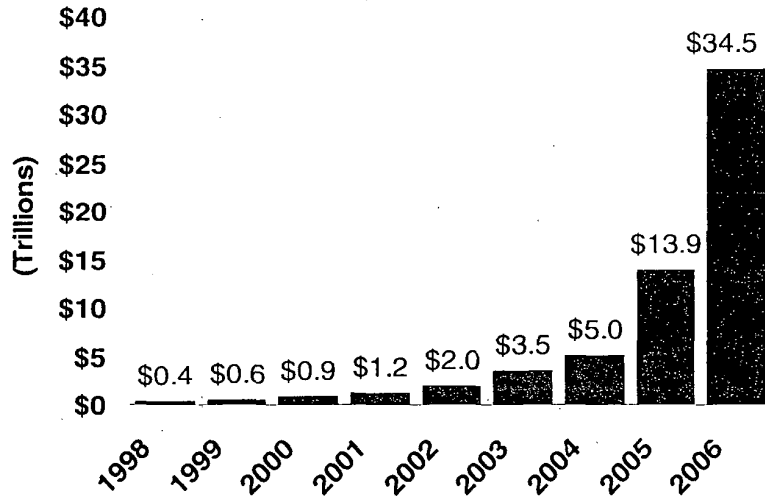

Source: British Bankers Association

PROPRIETARY AND CONFIDENTIAL -
CONFIDENTIAL TREATMENT REQUESTED
BY FANNIE MAE

Confidential - Internal Distribution

24

Confidential Treatment
Requested By Fannie Mae

FMSE 720722

These innovations have occurred outside of Fannie Mae and they are not without concerns about the risks they pose. At Bear Stearns, for example, two hedge funds managed by the firm experienced severe losses on highly leveraged portfolios of exotic subprime mortgage securities. Despite debacles such as the one at Bear Stearns, the long-term trend is for the increased use of these tools and adoption by mortgage investors.

Accordingly, we now face competition not just from Freddie Mac, but from a broadening variety of investors, intermediaries, customers and others:

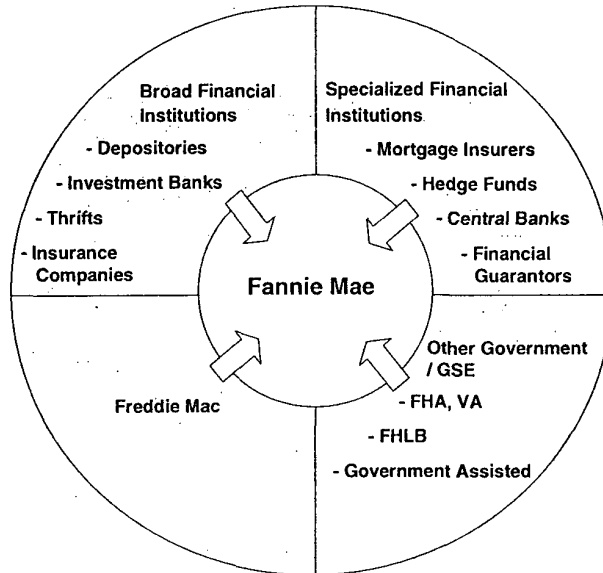

Most identifiable competitor – Freddie Mac – is neither the nor the greatest threat

The choices we are making in our strategic plan take into account the competitive pressures arising from both ongoing industry consolidation and disintermediation by the capital markets. We believe that we should position Fannie Mae to move into higher credit-risk arenas to offset the margin compression being forced on us in our traditional, low credit-risk segments by our ever-larger customers. Managing more credit risk through risk transformation and other creative methods will also strengthen Fannie Mae's competitive position as the intermediary of choice for bringing capital to U.S. housing.

Winners in this market environment will have the capabilities to price and retain credit risk they like and distribute the remaining risk to others that value it more. This requirement means building stronger credit capabilities in both the Single-Family and HCD businesses. While we have made modest steps in that regard, more ambitious ones are necessary and are reflected in the strategic plan.

**PROPRIETARY AND CONFIDENTIAL –
CONFIDENTIAL TREATMENT REQUESTED
BY FANNIE MAE**

Confidential - Internal Distribution

25

**Confidential Treatment
Requested By Fannie Mae**

FMSE 720723

Our 2007 to 2011 plan assumptions, therefore, include the following:

Strategic Plan Assumptions					
Variable	2007	2008	2009	2010	2011
Real GDP growth	2.5%	3.0%	3.2%	3.3%	3.3%
Short-term rates ¹	4.88%	4.50%	4.6%	4.6%	4.67%
Long-term rates ²	4.68%	4.78%	4.89%	4.98%	5.05%
Inflation ³	3.1%	2.5%	2.4%	2.4%	2.4%
House price growth ⁴	-1.0%	1.5%	2.9%	4.3%	5.7%
Home sales growth ⁵	-7.1%	1.3%	1.7%	3.1%	4.3%
Originations (\$ trillion)	\$2.63	\$2.33	\$2.24	\$2.35	\$2.51
MDO growth	6.4%	5.4%	5.3%	5.5%	5.8%

¹ Yield on 3-month Treasury bill.

² Yield on 10-year Treasury note.

³ Consumer Price Index (total).

⁴ Fannie Mae house price index.

⁵ New plus existing sales.

**CONFIDENTIAL AND CONFIDENTIAL -
CONFIDENTIAL TREATMENT REQUESTED
BY FANNIE MAE**

Confidential - Internal Distribution

26

**Confidential Treatment
Requested By Fannie Mae**

FMSE 720724

The Three “Big Questions”

As we solidified assumptions about market conditions for the plan period, we found that we were stymied by three issues we called the “big questions.” These questions, although long-term in nature, presented near-term crossroads and therefore needed resolution. These originally emerged from discussions with Directors during our preparation meetings. The first and most profound is, should we consider relinquishing the charter, both in benefits and requirements, and “privatize” the company? Second, what should we do with the mortgage portfolio – is the size more trouble than it’s worth, and should we – as some critics suggest – reduce it? Third, as we determine where to take our business within the charter, what is our *raison d’etre* – what do we do, and do well, that we should focus on more?

Question 1 - Is privatization an available path?

- *The charter delivers significant value to shareholders; no viable alternative during this strategic period replaces that value.*
- *Investing major resources in evaluating privatization does not make sense for the planning horizon.*
- *Privatization should be the subject of periodic updates or “fresh looks” as time or events dictate.*
- *The recommended strategy will build capabilities that would remain relevant under either privatization or the charter.*

This question is not new. We have asked it on and off for at least 20 years. Most recently, the Board commissioned Citigroup and McKinsey & Co. to independently perform “Project Phineas” in 2005 to look at the charter’s value to shareholders. It again affirmed that the charter’s value was greater than any viable non-charter scenario.

**Shareholder Value Derived from the Charter
(2005 Analysis)**

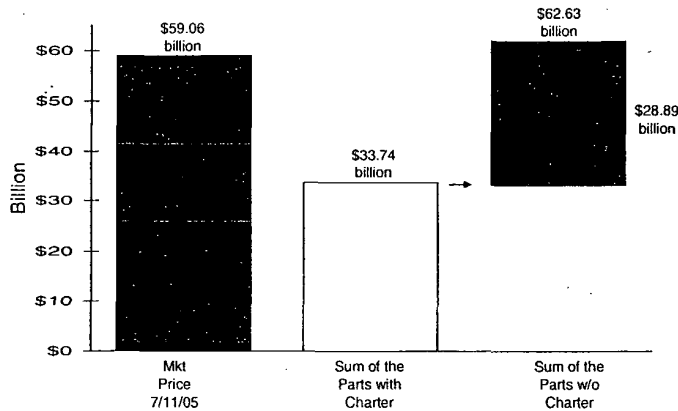

We updated the 2005 analysis again this year and concluded that, in fact, there had been no erosion in the \$30-plus billion of shareholder value inherent in our charter and the

**PROPRIETARY AND CONFIDENTIAL -
CONFIDENTIAL TREATMENT REQUESTED
BY FANNIE MAE**

Confidential - Internal Distribution

27

**Confidential Treatment
Requested By Fannie Mae**

FMSE 720725

capabilities we have built in order to fulfill that charter. While value creation is the purpose of this plan, if it zero sums with value erosion (charter or otherwise), then we go back to the drawing board.

The promise of privatization contemplates the notion of increased business opportunities through both vertical growth and diversification of products and markets. Vertical growth includes the prospects of moving into, for example, mortgage origination, mortgage servicing, or asset distribution. Diversification includes moving into, for example, jumbo mortgages, international markets, or asset management. While some of these opportunities are technically permitted within the charter today, in practice they are not pursuable without significant operational, financial, or political risk.

The promise of privatization also contemplates a greater ability to adapt to a changing marketplace, which involves greater flexibility, creativity, and innovation.

Our analysis of privatization looked at three models: 1) Sallie Mae's transition from a GSE to a hybrid public/private structure; 2) creating a separate company; and 3) creating a GSE holding company.

1. Sallie Mae – In brief, Sallie Mae was a GSE established to provide a market in student loans, which effectively relinquished its charter and formed a “Newco” after facing a prohibitive user fee as the cost of keeping its status. There are important differences between Sallie Mae during its privatization and Fannie Mae today. Size and market impact is a major difference; Sallie Mae managed \$80 billion in student loans; Fannie Mae's book of business is \$2.6 trillion and mortgage portfolio more than \$700 billion. Sallie Mae's market capitalization was \$2.4 billion; Fannie Mae's is more than \$65 billion. Sallie Mae's primary constituents were student borrowers; Fannie Mae's are housing advocates, lenders, developers, builders, debt and equity investors, and more. Congress passed legislation that imposed costs on Sallie Mae that were greater than the value of its charter; Fannie Mae's charter continues to have value greater than the costs. Sallie Mae was the only GSE under its then charter; Fannie Mae's competitor, Freddie Mac, operates under the same charter and, therefore, related decisions affect and require the agreement of both companies. Sallie Mae's management had more freedom of movement, with both Congressional acquiescence and virtually no market opposition; those conditions do not exist for Fannie Mae. So, while we can learn from Sallie Mae, its experience is less useful as a blueprint for us.
2. Creating a separate company – Liquidating the company, taking selected operations or assets and starting a new Fannie Mae without its current GSE obligations and/or existing assets is a concept that essentially would represent “turning in the Charter.” This obviously would be impossible without Congressional approval, which we judge unlikely absent a crisis more severe than 2004-2005. Having experienced a full spectrum of political alignments from the 1992 legislation until now, our assessment (and that of our advisors) is that there has never been serious impetus toward “permissive privatization.”

**PROPRIETARY AND CONFIDENTIAL –
CONFIDENTIAL TREATMENT REQUESTED
BY FANNIE MAE**

Confidential - Internal Distribution

28

**Confidential Treatment
Requested By Fannie Mae**

FMSE 720726

3. Creating a GSE holding company – Allowing Fannie Mae to create new business entities separated from obligations of the charter while retaining GSE status for some or all of the current company essentially is a “bank holding model.” For the reasons above, this concept also is unlikely to gain traction.

In summary, Congress decides whether we can privatize. If it ever seriously considered this option, it almost certainly would seek an exit fee, a user fee on the total book of business, severe portfolio limits, elimination of a critical securitization instrument – the TBA execution – or other equally adverse steps. There might be a long lead time for the company to prepare, at least 5-10 years.

In 2005, the market environment was at its peak for the prospects of Congressional action. The politics of the Congressional majority, the Administration, and the Federal Reserve were aligned. The voice of critics was fueled by the accounting crises at the GSEs. Competitors were taking share while the market was hungry for capital and suppliers had the appetite to take in increasing mortgage risks. Yet, amid “ideal dynamics” for privatization, Congress could not enact reform legislation in which there was general agreement on key provisions. And two years later, the market and policy response to the meltdown of the subprime market indicates that the GSEs continue to be important to the stability of U.S. housing.

Our conclusion is that Congress would rather have a regulated entity supporting U.S. housing and does not fully trust the private sector to bear that responsibility alone. Furthermore, the current draft legislation, which includes a provision for an affordable housing fund, would potentially add new stakeholders to the GSEs.

However, so long as we retain any form of GSE status, we will no doubt be criticized. We are too big and occupy too many mortgage crossroads to be out of sight or out of mind. We will respond to fair criticism, and will have to bear some unfair or invidious commentary. Ultimately, though, a big bet on privatization should be, in my view, about a big economic return, not about paying for silence. In that regard, given our positive growth prospects, neither alternative business model nor disinvesting the present one makes sense. The proposal, then, is to execute the maximum potential of the strong model we have built.

We will continue to think about privatization creatively and monitor the economic value of the charter. We will reassess the question regularly, but will not devote major resources to it unless the math changes. That said, we also believe that the activities we need to undertake to maximize in-charter opportunities basically are consistent with those we would develop to operate without the charter. Under any scenario, completing remediation, overhauling our systems and energizing a competitive culture are mandatory. We did not uncover attractive business activities of scale – outside the charter. That made sense for us to develop while skipping over as-yet undeveloped in-charter activities. For example, consumer banking, mortgage origination, broker-dealer and financial assurance are all plausible activities – but ones even well-established firms are struggling to rationalize.

**PROPRIETARY AND CONFIDENTIAL -
CONFIDENTIAL TREATMENT REQUESTED
BY FANNIE MAE**

Confidential - Internal Distribution

29

**Confidential Treatment
Requested By Fannie Mae**

FMSE 720727

In conclusion, absent a clear proposition to garner \$30 billion of market value to replace the estimated charter value we would lose, we do not recommend a change for the present.

Question 2: Should we reduce the mortgage portfolio?

- *Shrinking the portfolio poses serious risks to the credit guaranty businesses.*
- *Size of the portfolio should be driven by economics of returns vs. cost of capital, not an arbitrary level.*
- *We will manage and measure the portfolio differently.*

We tackled the proposition of reducing our \$725 billion mortgage portfolio to, for instance, \$300-\$500 billion, the size contemplated in legislative proposals by those critical of the portfolio function. Put in strategic terms, we asked whether we should undertake a major re-allocation of the company's capital.

We began with a set of "champion/challenger" questions about the portfolio:

- Capital and returns. The portfolio consumes 55-60 percent of the company's regulatory capital. While our 30 percent regulatory capital surplus is in effect, the portfolio is projected to continue producing returns at around our 9-10 percent cost of capital. GAAP income is forecasted to contract, with single-digit GAAP return on equity. Would the shareholders rather have their money back, instead of seeing it earn at only around our cost of capital?
- Risk. An instantaneous 200 basis point change in interest rates produces a \$9 billion loss in the company's fair value. A 10 basis point widening of the mortgage/debt spread produces a \$3 billion loss in the company's fair value. The portfolio should earn roughly \$2 billion in fair value per year and \$1.5 billion of GAAP net income. At those returns, are the risks and reported volatility of the company's results worth it?
- Political lightning rod. The Federal Reserve, OFHEO, the Treasury, the White House and key members of Congress all take issue with the portfolio. Would it actually provide value to shareholders to take this issue off the table?
- Value proposition. Some say neither we nor Freddie Mac yet have been able to provide investors with a compelling rationale (or understandable metrics) for the value proposition of our portfolios. Could we remove a discount on the stock by making the mystery smaller?
- Been there, done that. The \$200 billion reduction in the portfolio in 2005 was a test case – nothing negative appeared to occur to the company or to the market.

PROPRIETARY AND CONFIDENTIAL -
CONFIDENTIAL TREATMENT REQUESTED
BY FANNIE MAE

Confidential - Internal Distribution

30

Confidential Treatment
Requested By Fannie Mae

FMSE 720728

We then pursued the other side of the hypothesis and looked at a second set of questions:

- Opportunities arise: We know that exceptional double-digit growth opportunities arise for the portfolio from time to time. If we diminish our portfolio infrastructure by shrinking it, will we leave profit potential on the table when opportunities do strike?
- Competitive position: How much downside is there to cede the liquidity advantage and potential investor and dealer interest in our debt to Freddie? What unintended consequences might occur, and spill over to our other businesses, if Freddie gains a material leadership advantage?
- Strategic reality. Our charter limits us to only two basic businesses: guaranty and portfolio. Do we really want to get rid of a \$500 billion business? Do we want to cast our lot with only one business? Moreover, if the 30 percent capital surcharge goes away, our expected returns clearly exceed our cost of capital.
- Support to other businesses, including the "price spread": With a \$300-\$500 billion portfolio, could we support the MBS, the key to our success in Single-Family and support Single-Family and HCD whole loan purchases and support housing goals and have capacity left over to earn good returns?
- Administrative costs: Total direct costs for the portfolio are about \$230 million, almost all of which are fixed. Consequently, there is no "cost" advantage to shrink (while conversely there are cost benefits to growing).

Weighing these pros and cons, we decided that overall, there are significant "throw the baby out with the bathwater" issues involved in shrinking the portfolio, while there are critical benefits to maintaining its size and ability to grow when opportunities arise. These reasons include:

1. Potential returns. When the 30 percent regulatory capital surplus is lifted, which we believe could happen as early as next year, the returns on the portfolio would rise well above our 9 to 10 percent cost of capital. While reducing the portfolio would produce a somewhat larger return on equity, that benefit would be offset by the lost earnings potential.

**PROPRIETARY AND CONFIDENTIAL -
CONFIDENTIAL TREATMENT REQUESTED
BY FANNIE MAE**

Confidential - Internal Distribution

31

**Confidential Treatment
Requested By Fannie Mae**

FMSE 720729

The Returns of the Portfolio

The Economics of the Portfolio

	Returns with 30% Surplus		Returns without 30% Surplus	
OAS	0.25%	0.30%	0.25%	0.30%
Earnings on Invested Capital	0.13%	0.13%	0.10%	0.10%
Less: Direct Admin Expense	-0.030%	-0.030%	-0.030%	-0.030%
Pre-Tax Income	0.35%	0.40%	0.32%	0.37%
After-Tax Income	0.23%	0.26%	0.21%	0.24%
Less: Cost of Preferred:	-0.03%	-0.03%	-0.02%	-0.02%
Income Available for Common Shareholders	0.20%	0.23%	0.19%	0.22%
Regulatory Capital Requirement	2.05%	2.05%	2.05%	2.05%
Regulatory Surplus	30%	30%	0%	0%
Total Capital Required	2.67%	2.67%	2.05%	2.05%
% of Preferred in Capital Structure	20%	20%	20%	20%
Required Common Equity	2.13%	2.13%	1.64%	1.64%
Return on Equity	9.37%	10.89%	11.38%	13.36%
Earnings Rate on Invested Capital	5%	5%	5%	5%
Cost of Preferred Stock	5.6%	5.6%	5.6%	5.6%
Tax Rate	35%	35%	35%	35%

2. MBS price advantage. The market traditionally has priced Fannie Mae's MBS better than Freddie Mac's; on a pass-through certificate yield, the difference has been 3 basis points so far in 2007. This three-point advantage, when added to our guaranty fee, comes to \$600 million in annual revenue on a \$2 trillion book (or a present value of \$2.5 billion). While hard to measure, it is clear that our portfolio's ability to purchase Fannie Mae MBS supports the demand and price of our security, so a smaller portfolio would be less able to purchase our MBS and support our price spread.

The Price Spread:

- 2007 Average Fannie Mae MBS yield: 5.68%
- 2007 Average Freddie Mac PC yield: 5.71%
- Fannie Mae price advantage: 3 bps

The Value of the Price Spread:

- Value of 3 bps price advantage, as addition to Guarantee Fee
 - Annual Revenue on \$2 trillion: \$600 million
 - Present Value: \$2.5 billion

**PROPRIETARY AND CONFIDENTIAL -
CONFIDENTIAL TREATMENT REQUESTED
BY FANNIE MAE**

Confidential - Internal Distribution

32

**Confidential Treatment
Requested By Fannie Mae**

FMSE 720730

3. Support for customers. The portfolio's ability to support our Single-Family and HCD customers – and our affordable lending efforts – by purchasing whole loans and securities is critical; shrinking the portfolio could pose serious risks to these businesses. In addition, we may be asked to stabilize markets with additional capital. A \$100 billion surge on a large portfolio (e.g., \$700 billion) can be absorbed more readily than on a small portfolio.

Therefore, we decided we should *not* have a bias to reduce substantially the size of the portfolio, and at present do not have a compelling economic argument to shrink it. This decision does not mean that the portfolio will never shrink; if returns are clearly less than our cost of capital, we should shrink. If the returns are good, we should grow. The simple answer about the portfolio, therefore, is we will “follow the economics.”

Deciding that, we also believe the value proposition for the portfolio should include the following elements:

- Long-term growth expected to be on pace with mortgage debt outstanding, projected above U.S. economic growth.
- Expected adjusted rate of return on equity close to double digit with 30 percent capital surplus, and in excess of double digit without the capital surplus.
- These returns will be observable in the fair value metrics of the company.
- The duration gap will remain close to zero, and other risk metrics on the low side of typical market ranges.
- Consistent with “Big Tent” Mission – reinforce liquidity and stability role.
- Continue to work on market perceptions of the portfolio.

Question 3: What is our *raison d’etre* – where should we focus?

- *We should continue to be the most effective distributor of global capital to U.S. housing.*
- *We should focus our business on the activities that deliver the greatest value measured by risk/return.*
- *Our best opportunity for business and mission is in expanding securitization and credit risk management.*

After addressing and resolving the big questions about the charter and mortgage portfolio, we asked an organizing question: Can we identify a central, unifying “theory of the firm” to define our strategy?

We chose the term *raison d’etre* to emphasize the broader nature of the question, rather than the practical reasons we exist (e.g., to provide affordability or liquidity). It is important for established companies, as they map their future course, to step back and evaluate their purpose in order to strengthen it. In our case, it means encompassing business and mission.

In doing so, we determined that Fannie Mae’s business mission, in the broadest sense, is to be the most effective distributor of global capital to housing in the United States. Our

**PROPRIETARY AND CONFIDENTIAL –
CONFIDENTIAL TREATMENT REQUESTED
BY FANNIE MAE**

Confidential - Internal Distribution

33

**Confidential Treatment
Requested By Fannie Mae**

FMSE 720731

primary business supports middle-income homeowners but we also enable affordable housing, and smooth out fluctuations in housing finance. We want to operate within the charter, and believe that fulfilling our business mission should fulfill the charter mission.

With that broad reason for our existence, we then sought to determine the focal point of Fannie Mae's business. A traditional approach to strategic planning looks at types of companies that provide corollary business models to consider. In that regard, we determined that Fannie Mae's actual business activities are comparable to three different business models:

- A utility, or processor/secritizer, in that we convert loans into securities for mortgage originators. This lowers mortgage rates, provides liquidity to the market place. Here we are similar to Freddie Mac, Bear Stearns, Sallie Mae and Capital One.
- An investment company, in that we manage market risk by funding with agency debt and investing in loans and securities, and we earn a spread for managing mortgage cash flow, providing liquidity and taking market risk. Here we are similar to JP Morgan Chase, Citi, Bank of America, real estate investment trusts (REITs) and Freddie Mac.
- An insurance company, in that we guarantee (or insure) mortgage payments to investors, and accept mortgage default risk. Here we are like MGIC, PMI, Radian, UGI and again, Freddie Mac.

Because no individual business model was a complete corollary to Fannie Mae, we, instead, looked at the primary functions performed by those companies. Across the three business models were four functions common to the three and to Fannie Mae – securitization, interest rate risk management, mortgage cash flow risk management (also referred to as spread investing), and credit risk management.

Which functions provide the highest returns for risk? The answer at a summary level is as follows:

Different Corporations Emphasize Different Functions				
Functions vs. Returns Generated				
Corporate Comparisons	Securitization	Interest Rate Risk	Spread Investing	Credit
Utility/Processor/Secritizer	High	Low	Moderate	Moderate
Investment Company	Low	Moderate	High	High
Insurance Company	Moderate	Low	Moderate	High

**PROPRIETARY AND CONFIDENTIAL –
CONFIDENTIAL TREATMENT REQUESTED
BY FANNIE MAE**

Confidential - Internal Distribution

34

**Confidential Treatment
Requested By Fannie Mae**

FMSE 720732

Which function(s) should be the emphasis in Fannie Mae's strategy going forward? An easy answer is that we should emphasize those functions with the highest returns for risk, and create shareholder value. The harder questions, however, are which functions have the best return/risk ratio for Fannie Mae? Which functions can be expanded most? Where do we have the greatest opportunities with the greatest competitive advantages?

To answer those questions, we first examined how much emphasis our corollary companies – utilities, investment companies and insurance companies – place on each function and why. Clearly, they emphasize particular functions that generate the highest returns. Utilities emphasize securitization. Investment companies emphasize spread investing. Insurance companies emphasize credit.

We examined each function as follows:

- **Securitization:** This “fee for service” business has very low risks, mainly operational in nature. It is a “scale” business, maintained by size. It is crucial to our charter function to provide liquidity to the housing finance system. And the diversification of the mortgage originator base enhances our value to the market. However, given our current 25 percent market share and leadership in the MBS market, it would be tough to grow significantly. Our MBS business is most closely identified with 30-year mortgages, which are now among a wide variety of consumer choices. Its relevance is less tangible to communities. It must be buttressed by our portfolio balance sheet to ensure its liquidity and stability. It also is sensitive to anomalous prepayment of loans that comprise the securities and, therefore, reduce anticipated revenue streams.

Securitization provides good returns relative to risk, but can be tough to grow.

- **Interest rate risk management:** In the past, Fannie Mae has achieved strong but also variable returns on this function. As discussed, it is incidental or necessary to support mortgage investment. We expect it to generate returns from owning the shape of short- to long-term rates (the yield curve) and, possibly, from selling long-dated volatility. The variability can be quite high, and can be exposed to long-dated volatility from prepayments. We believe there is little or no comparative advantage for a GSE in managing interest rate risk, as it can be easily hedged in the market, and therefore the stock market is unlikely to give it a high P/E premium for success. Finally, growing the balance sheet as a GSE per se has become politically unattractive.

Interest rate risk management provides an ambiguous ratio of returns relative to risk.

**PROPRIETARY AND CONFIDENTIAL –
CONFIDENTIAL TREATMENT REQUESTED
BY FANNIE MAE**

Confidential - Internal Distribution

35

**Confidential Treatment
Requested By Fannie Mae**

FMSE 720733

- **Mortgage cash flow risk management:** This function, also known as spread investing, provides consistently good returns, and indeed provides a strong ratio of returns to risk over the long term. It has a reasonable P/E as a relatively low risk strategy. It is driven in part by generating liquidity through selling agency debt to buy mortgages, and so is another part of the liquidity business. Risk premiums historically are higher than losses. However, it cannot be grown rapidly at attractive levels, and can be reactive to the market and, therefore, undesirably subject to market vagaries. Also, at Fannie Mae, this function has been driven by the “science” of generally reliable models, with little reliance on individual decision making or judgment. It is not easily hedged in the market; we must hold investments for several years; and it expands or shrinks with market demand or supply, so it cannot grow with predictability.

Mortgage cash-flow risk management provides good long-term returns but is not easy to grow.

- **Mortgage credit risk management:** Generally will provide good returns, though with increased volatility. Our credit risk profile can be expanded rapidly when market opportunities exist. An expanded credit risk appetite increases affordable lending, supports our securitization programs, and, most importantly, gives us more relevance and tangibility with our lender customers. However, appropriate credit risk pricing relies on the intelligent use of models in making business decisions and on the intelligent use of business knowledge in building models. Moreover, the limited range of available credit risk management tools restricts hedging opportunities, forcing a strong reliance on a buy-and-hold strategy. We can, however, leverage our loss mitigation and real-estate owned (REO) capabilities as well as our real estate market knowledge to efficiently manage the credit risk portfolio. An expanded credit risk appetite provides opportunities to grow by further leveraging our market position and expanding our customer relationships.

Mortgage credit risk management provides good returns relative to risk over long-term and is easier to grow than other options.

Four internal Fannie Mae teams each championed one model to evaluate and prepare a set of recommendations that were discussed in depth at the senior management offsite. They analyzed each against a common set of criteria, with the finding summarized in the table on the next page.

**PROPRIETARY AND CONFIDENTIAL -
CONFIDENTIAL TREATMENT REQUESTED
BY FANNIE MAE**

Confidential - Internal Distribution

36

**Confidential Treatment
Requested By Fannie Mae**

FMSE 720734

Our Comparative Advantages Across Options Going Forward

	Securitization	Interest Rate Risk Management	Mortgage Cash Flow Risk Management	Credit Risk Management
Do we have a market advantage? ▪ Liquidity ▪ Scale ▪ Expertise	H H H	H H M	H H H	H H M/L
What are the opportunities? ▪ Growth of market ▪ Growth of share ▪ Market pricing	M M L	M L L	M L M/L	M H H
Can we generate value added to the shareholder? ▪ Will the market pay us a premium ▪ Growth ▪ Consistency of earnings ▪ Risks	H M H M/L	L M L H	M M L M	H H M M
How mission rich is the activity? ▪ Affordable housing ▪ Stabilization ▪ Tangibility to communities	L H L	L L L	M H L	H M M
What conflicts will the activity create? ▪ Commercial ▪ Regulatory ▪ Political	L L L	L H M	H H H	H H H

(H=High; M=Medium; L=Low)

As our analysis showed, all four activities bring some degree of value to the company, some a high degree. Therefore, we are not eliminating any one of these as a business activity, but instead choosing which ones to emphasize during the course of this strategic plan.

From the chart above, it is clear that – on balance – securitization and credit risk management, offer the most “High” and “Medium” comparative advantages for Fannie Mae for the first four of the five categories above. Those results make analytical sense and common sense. Our securitization business has produced the most highly valued, liquid mortgage-backed securities in the marketplace. Our credit risk management has produced unusually low credit losses for our business year after year, and the average mortgage in our book has relatively low loan-to-value ratios (less than 60 percent, weighted average) and high credit scores (720 FICO). In both areas, we have a distinct competitive edge and room to do much more.

Therefore, we believe that focusing more emphasis on credit risk management and securitization should be an organizing purpose for our business and our mission, given: 1) our market advantages in these activities; 2) our opportunities to grow the business through these activities; 3) the added value we can generate for shareholders; and 4) the high value they offer for our affordable housing mission.

**PROPRIETARY AND CONFIDENTIAL –
CONFIDENTIAL TREATMENT REQUESTED
BY FANNIE MAE**

Confidential - Internal Distribution

37

Confidential Treatment
Requested By Fannie Mae

FMSE 720735

The Strategic Choice – Broaden and Deepen

After determining where we are, who we are, our strategic opportunities and answers to the big strategic questions, our strategic path for the next three to five years became much clearer. We have a solid franchise – we can do more with it. We have room to grow within the charter – we must find the most optimal segments to mine. Examining our raison d’etre, we have determined that the greatest opportunities for our mission and business, in terms of risk, return and value, are in securitization and credit risk management.

Therefore, we have chosen a strategy that rests on three pillars:

1. As we grow with the growing mortgage-debt market, we will also grow our share of the market by going deeper into segments where we have only scratched the surface.
2. As we preserve the value and advantage of our securitization business, we will also expand this business.
3. As we preserve and build up our credit risk management abilities, we will increase our breadth in managing credit risk in areas where we have little presence. There are 11 areas in particular – subprime, Alt-A and seconds; acquisition, development and construction lending; multifamily equity; small multifamily properties; commercial mortgage-backed securities; securities below AAA-rated; mezzanine debt; and reverse mortgages.

In other words, for the next three to five years, we will both deepen our reach in traditional businesses that we hold leadership positions in already – credit guaranty, securitization, Capital Markets – as we broaden our reach by finding new areas to develop. We will go from “The Egg,” shown in Figure 1, to the “3-D Egg,” shown in Figure 2.

Figure 1 – “The Egg”

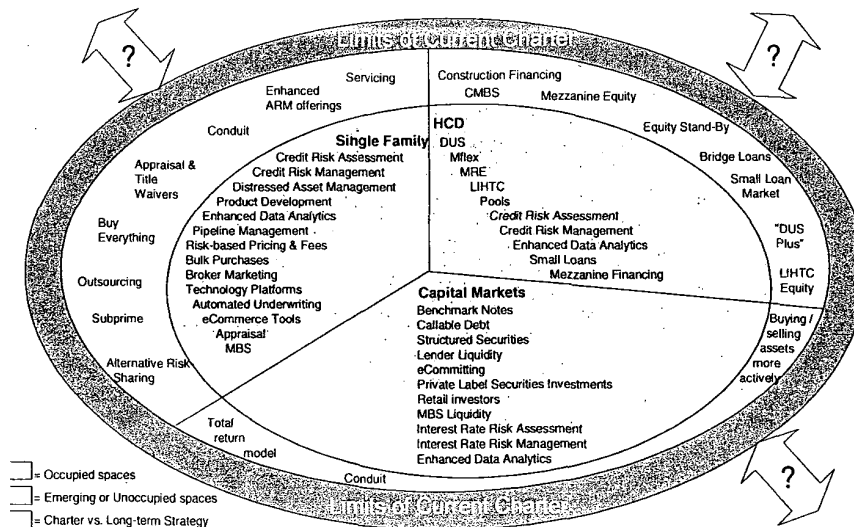

**PROPRIETARY AND CONFIDENTIAL –
CONFIDENTIAL TREATMENT REQUESTED
BY FANNIE MAE**

Confidential - Internal Distribution

38

**Confidential Treatment
Requested By Fannie Mae**

FMSE 720736

Figure 2 – The “3-D Egg”

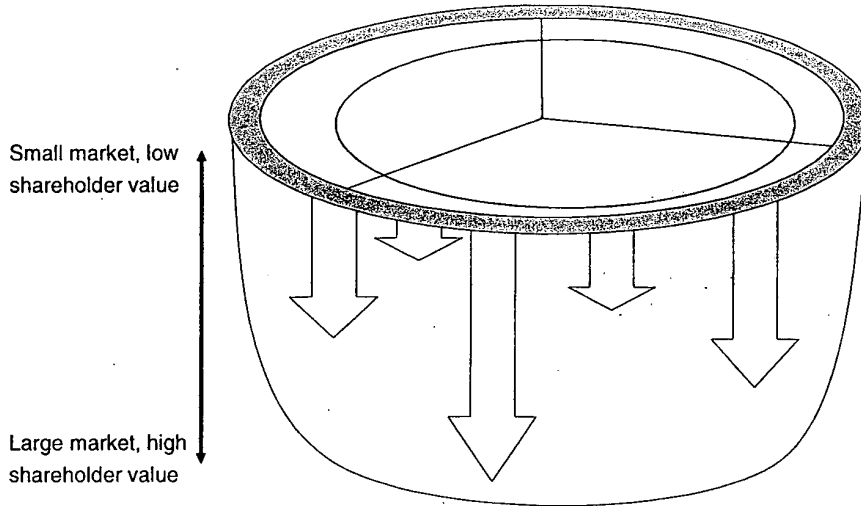

We believe there is tremendous opportunity in deepening our reach in traditional businesses we are leaders in, and broadening our reach to find new areas to develop, in 11 specific areas. Our forecast of the average annual incremental industry profit for each, where estimates are possible, is shown in the chart below.

Industry Profit Pools

	2007 forecast (\$ billion)	2011 forecast (\$ billion)
Subprime	\$4.0	\$3.8
Alt-A	\$1.9	\$1.6
2nds	\$1.1	\$0.9
Small MF	\$0.2	\$0.2
Equity	n/a	n/a
AD&C	\$4.6	\$4.6
CMBS	\$0.1	\$0.1
<AAA securities	\$0.5	\$0.4
Mezzanine debt	n/a	n/a
Reverse mortgages	<\$0.1	<\$0.1

Source: Fannie Mae Business Strategy

**PROPRIETARY AND CONFIDENTIAL –
CONFIDENTIAL TREATMENT REQUESTED
BY FANNIE MAE**

Confidential - Internal Distribution

39

**Confidential Treatment
Requested By Fannie Mae**

FMSE 720737

- **Summary: The strategy process and results**

So far this strategic plan has outlined the steps we have taken leading to the choice we have made about our strategic path for the next three to five years.

As the diagram below illustrates, we began the process by stating the purpose of Fannie Mae, answering the question of why we exist. From there, we addressed our mission in the context of what we do, and then provided a vision reflecting the aspirations we have for the company.

Summary: Multilevel Alignment

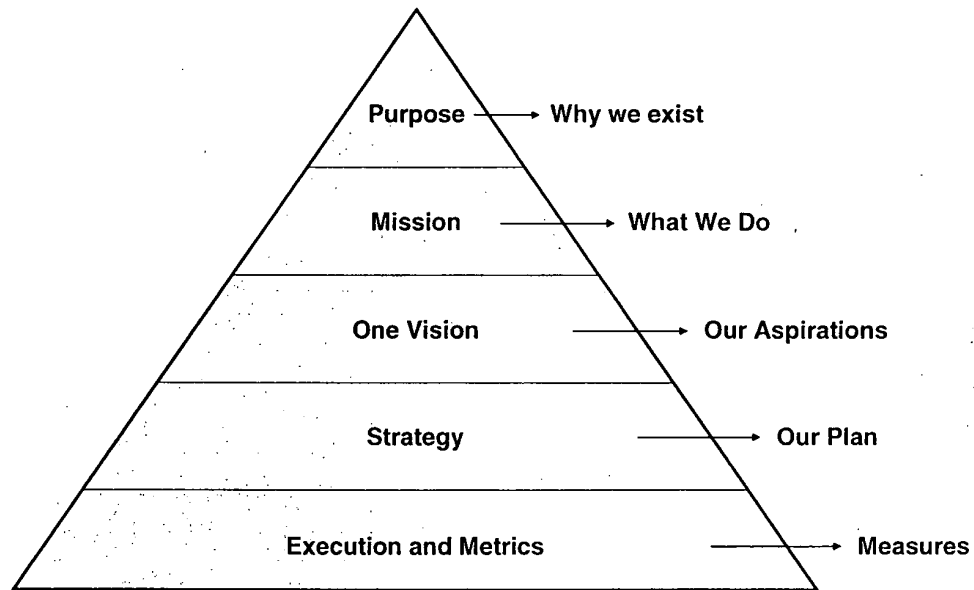

The sections that follow address our strategy to achieve that vision and the measures to evaluate the progress against that strategy.

**PROPRIETARY AND CONFIDENTIAL -
CONFIDENTIAL TREATMENT REQUESTED
BY FANNIE MAE**

Confidential - Internal Distribution

40

**Confidential Treatment
Requested By Fannie Mae**

FMSE 720738

**How We'll Get There –
Business Plans, Mission Impact**

**Confidential Treatment
Requested By Fannie Mae**

FMSE 720739

Section IV: How We Will Get There – Business Plans, Mission Impact

- *We will expand capacity to securitize and purchase more credit-sensitive assets.*
- *Single-Family and HCD will take the lead, supported by Capital Markets.*
- *This strategy will provide greater access to mission-rich mortgage assets.*

The next step in our strategic planning is to “operationalize” the direction by formulating specific business strategies. Our plan to pursue more opportunities for securitization and credit risk management will require each business – Single-Family, HCD and Capital Markets – to undertake new approaches, new investments, and a new mindset that *managing mortgage credit risk is our sweet spot – we need to do more of it, and do it better, for our business and our mission.* The plan also demands that the three businesses operate as One Fannie Mae.

- What we are going to do: We will support the expansion of the breadth and depth of the credit guaranty businesses. Single-Family and HCD will expand further across the credit spectrum in securitization. Capital Markets will acquire more credit-sensitive loans for the portfolio, and use the balance sheet to generate cash flow risk management earnings, maintain MBS liquidity, and acquire and manage part of our credit exposure. We will manage the credit risk of our loans on balance sheet, our MBS off-balance sheet and our investments in private label securities consistently. We plan to further improve the risk/return ratio by creating an off-balance sheet credit risk execution. Overall, we plan to build a best-execution mechanism to quickly bring in a broader array of credit-sensitive assets; quickly size, process and value the credit risk; and keep what we like and distribute out the risk we do not like through a variety of mechanisms.²
- What we expect to gain: This option offers market advantages, opportunities to grow and generate value for shareholders, and mission benefits:
 - The market advantages include our access to capital and cost of funds, data resources, and our broad access to mortgages through our nationwide customer base.
 - The opportunities to generate value added to shareholders include: 1) the market will pay us a premium for this function, since Fannie Mae most often is the preferred market execution; 2) the market would welcome our growth into credit segments that have more risk; and, 3) earnings would be stable and consistent because this is a sustainable business proposition.

² This plan will include completing the second and third phases of the Risk Transformation Facility launched in 2006 as a joint Single-Family/HCD/Capital Markets initiative. In Phase I, we developed the process to slice off and distribute credit risk in bulk mortgage securitization deals from a single lender. Phase II will allow risk transformation of bulk deals from multiple lenders. Phase III will allow risk transformation in “flow” business – daily deliveries of mortgage product from all lenders. This will give us the same capability that our private-label competitors have to manage credit risk.

**PROPRIETARY AND CONFIDENTIAL –
CONFIDENTIAL TREATMENT REQUESTED
BY FANNIE MAE**

Confidential - Internal Distribution

41

**Confidential Treatment
Requested By Fannie Mae**

FMSE 720740

- The mission opportunities include: 1) managing more credit risk would give us access to more affordable housing products; 2) allowing us to play a stabilizing force in these segments; 3) allowing us to provide tangible benefits to communities.
 - The projected financial results are attractive – the earnings outlook and key metrics – are provided in Section V, “How we will measure success.”
- What we need to do: Pursuing this opportunity to grow credit risk on- and off-balance sheet will create some conflicts to address. The greater challenge will be to create new capabilities within the company to take on more and different types of risk. These challenges include:
 - Credit models: We need to develop a better risk-based pricing methodology consistent with a broader risk spectrum. Generally, credit models are less reliable than our present prepayment models. Therefore, they must be transparent, not a “black box,” and the results must be internalized by credit decision makers, and used as a guide to decision-making.
 - Credit culture: Fannie Mae historically has had a business culture of avoiding credit risk; now we must take and manage more credit risk, and possibly accept losses that exceed historical levels. We need to buy and build long-term expertise of what can go badly in more credit sensitive sectors.
 - Competition and conflict: Taking more credit risk invariably means a changing business dialogue with mortgage insurers and investment banks, which not only creates competitive stresses with clients, but also political noise and resulting scrutiny. Keeping more risk will also require regulatory coordination. Business-wise, we also must view assertions of originators and lenders skeptically; price negotiations become increasingly critical in client relations. We will need to continue to build external relationships with all these parties that can withstand the likely stresses.
 - Infrastructure and One Fannie Mae: We plan to develop the back office technology to value, track and monitor our credit-sensitive assets, and build distribution channels (e.g., broker/dealer-like capability). We also plan, under our Risk Transformation Facility, to develop multiple outlets and strategies for risk we don’t want to hold. We will take an integrated business approach to reflect the market price of credit. When market prices change, we will adjust prices accordingly or risk losses in dollars or market share. We also need to tap into alternative market executions and capabilities.

**PROPRIETARY AND CONFIDENTIAL –
CONFIDENTIAL TREATMENT REQUESTED
BY FANNIE MAE**

Confidential - Internal Distribution

42

**Confidential Treatment
Requested By Fannie Mae**

FMSE 720741

Business Segment Plans: Single-Family, HCD, Capital Markets

The following sections describe how the three business units – Single-Family, HCD and Capital Markets – plan to carry out their part of the strategy.

Single-Family Mortgage Guaranty

The Single-Family business plans double-digit growth over the next five years by harnessing its inherent market advantages to increase credit risk-taking and distribution.

- Market environment: The housing and mortgage market corrections described in Section III trend favorably for our Single-Family business as mortgage risk pricing and underwriting become more rational, and demand for fixed-rate products increases. At the same time, the correction is causing many lenders to consolidate or move up the value chain into our business, giving them more pricing power.
- Strategy: We start in a strong position, having decided to step back from the surge in “layered-risk” subprime lending in 2003-2005 (not to mention the good luck of timing). As the market returns to rationality we are in an enviable position to assist our customers and grow our guaranty business.
 - Single-Family plans to regain and extend our market share and leadership, broaden and deepen our credit appetite; increase our risk distribution and execution capabilities; maintain our MBS “brand preference,” and help lender customers transform their processes via ease and speed of delivery, provide them with a dependable source of liquidity; and provide low-cost and dynamic speed of products to the market.
 - We will carry out these strategies by harnessing our competitive advantages in several areas: our nationwide distribution network of over 2,000 lender customers; the liquidity, safety and price advantage of our MBS; our role as a capital-rich and stable provider of funding; our integration with vendors and partners; and our data from the 16 million loans we “touch” – e.g., borrower behavior and loan performance we can use to build better scorecards; repeat sales data we can use to test collateral valuations and reduce appraisal “bias,” and prepay modeling for pricing, as well as real-time model adjustments and forecasting.
 - Our deep and broad lender relationships, when combined with our “business distribution mechanisms” (agreements and technology like DU), allow for a great deal of scalability. A new product or idea, once validated and formed, can be switched on readily and in size with almost every player in the mortgage market.
 - Generating significant volume and driving it through to MBS securitization can be done effectively. Additionally, this reach allows for a continuous market read in

**PROPRIETARY AND CONFIDENTIAL –
CONFIDENTIAL TREATMENT REQUESTED
BY FANNIE MAE**

Confidential - Internal Distribution

43

**Confidential Treatment
Requested By Fannie Mae**

FMSE 720742

terms of trends, new products and credit. The scale and liquidity of our MBS and the depth of our capital position ensure staying power in any cycle.

- Lenders see great benefit from the funding and capital advantage of our MBS; their ability to maintain "velocity" by quickly moving out pipelines into MBS and replenishing their ability to lend again is essential.
- As we ensure a high level of service and value and maintain our flow arrangements, we maintain the flow into MBS to keep that security very liquid.

What changes if we succeed – Single Family Strategy

	2007	2011
Credit Risk	Capable in conforming prime product, but under-skilled in other sectors	Skilled acquiring, pricing and managing credit across risk spectrum
Credit Losses	Low, little appetite; lots of back-end enhancement without best-execution	Higher losses; optimized backend, focusing on total return versus losses
Risk Distribution	Limited approaches, mainly M1's; generally buy-and-hold	Broad within the credit markets; buy, hold, and sell
Speed-to-Market	Slow response to major requests and market trends	Nimble, respond quickly to market changes
Operations	Older technology, labor intensive	More efficient systems and processes
Org design	Relatively silo-ed businesses	More cross-org activity

Housing and Community Development

HCD's business strategy is to increase the supply of affordable housing, primarily rental housing, by providing capital at all stages of the property lifecycle through both debt and equity investments.

Based on this strategy, the HCD business plans double-digit growth over the next five years by expanding its customer base, streamlining processes and strengthening our ability to take on more risk and price for it, including additional credit risk, construction risk, and risk associated with small borrowers.

HCD will continue to focus on low- and moderate-income families, while transforming a more mission-driven business into mainstream financing.

**PROPRIETARY AND CONFIDENTIAL –
CONFIDENTIAL TREATMENT REQUESTED
BY FANNIE MAE**

Confidential - Internal Distribution

44

**Confidential Treatment
Requested By Fannie Mae**

FMSE 720743

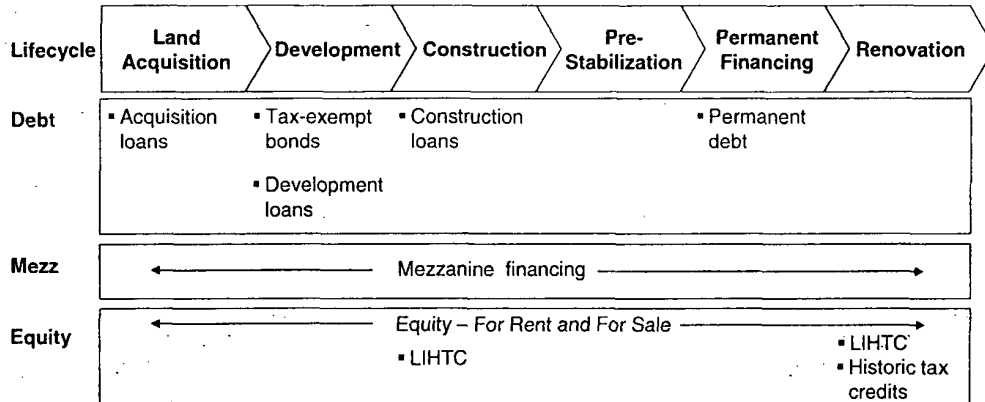

- **Market environment:** The variety and volume of capital flows into U.S. commercial real estate have increased dramatically over the past several years. Major factors include the increasing role of private equity capital, the privatization of formerly public REITS, conduits formed by Wall Street houses, and increased leverage. These changes have resulted in a market much more favorable for borrowers than the historical norm.

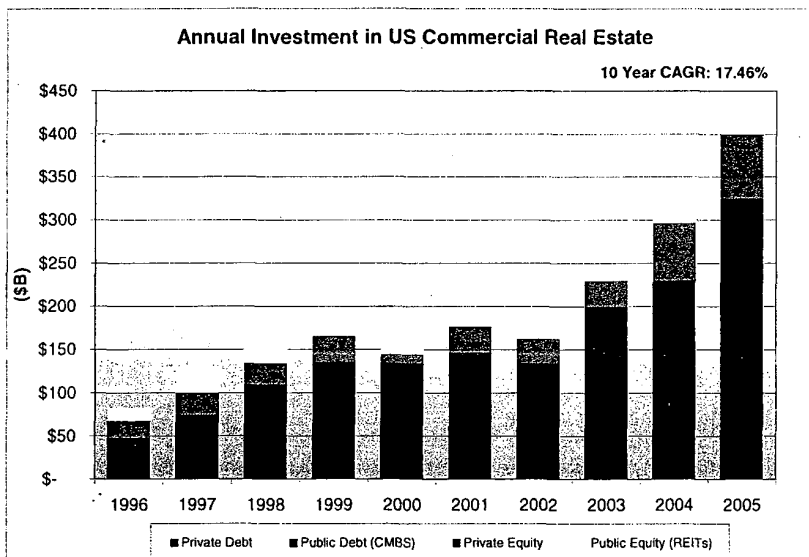

- **Strategy:** We will maximize our mature HCD businesses (multifamily and Low Income Housing Tax Credits (LIHTC), through both our Delegated Underwriting and Servicing (DUS) network and LIHTC fund manager partners.
- In 2008, our double-digit earnings projections are driven by our LIHTC and DUS multifamily businesses. Right now, our LIHTC business brings in about 60 percent of HCD revenues while serving families earning 60 percent or less of the area median income. Streamlining our DUS program and enhancing our LIHTC

**PROPRIETARY AND CONFIDENTIAL –
CONFIDENTIAL TREATMENT REQUESTED
BY FANNIE MAE**

Confidential - Internal Distribution

45

**Confidential Treatment
Requested By Fannie Mae**

FMSE 720744

delivery platform will help maximize our income in these mature businesses. We also will expand our customer base beyond our traditional business partners, to include non-risk-sharing lenders, investment banks, regional small multifamily lenders, intermediaries, equity funds and other commercial real estate investment partners.

- For 2009-2011, our projected earnings growth is driven by our Community Lending business and gains in our For Sale/For Rent equity business. In the For Sale/For Rent business, the company invests equity capital and earns a return (1) when completed homes are sold to homeowners, (2) when renovated or newly built apartment buildings are sold to operators, or (3) when we hold an investment in an operating apartment building and are entitled to a share of rental income. Our Acquisition, Development and Construction (AD&C) lending, mezzanine lending (involving loans subordinate to a first mortgage) and other new business initiatives will require strategic product development and differentiated customer management.
- Credit losses in HCD's business historically have been very low due to favorable market conditions and strict underwriting procedures. The increased competition in our market will require us to take on more risk, price it and transfer it to generate incremental revenue. We will investigate expanding our risk management through various types of financial instruments including our new Risk Transformation Facility (RTF), Collateralized Debt Obligations, and Credit Default Swaps. We expect modest increases in credit expense from a very low base due to growth and diversification of HCD business beyond our traditional focus on debt secured by first liens on operating rental properties. As depicted below, the incremental revenue we forecast from this expansion significantly exceeds the additional credit losses we expect.

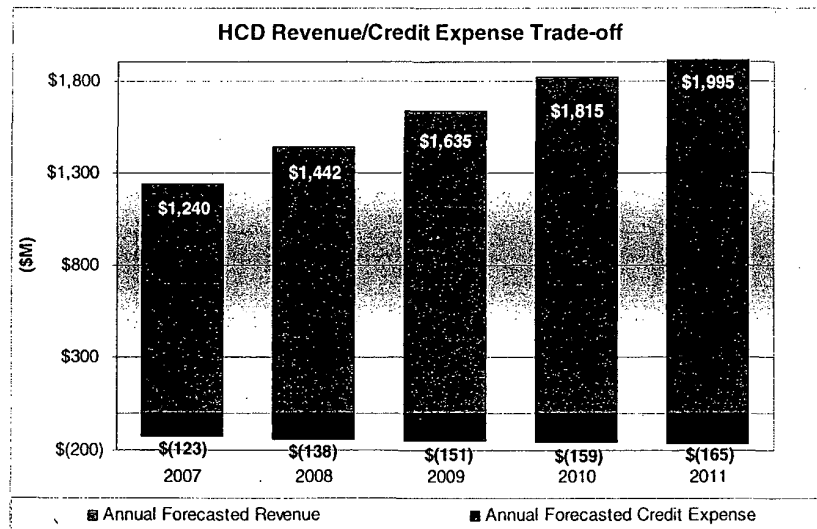

**PROPRIETARY AND CONFIDENTIAL –
CONFIDENTIAL TREATMENT REQUESTED
BY FANNIE MAE**

Confidential - Internal Distribution

46

**Confidential Treatment
Requested By Fannie Mae**

FMSE 720745

- Threats to this strategy include our ability to scale infrastructure to take on additional and new types of partners, a reduced company appetite or capacity to hold multifamily debt in portfolio, adverse changes to corporate earnings which impact our tax credit business, and a decline in market conditions for debt and equity investment in rental properties.

HCD Lines of Business

	2007-11 Forecast Growth	Opportunities	Risks
Multifamily/ Small Loans	3.0%	<ul style="list-style-type: none"> Expand business through new products and partners Streamline and strengthen infrastructure (DUS Redesign) 	<ul style="list-style-type: none"> Channel conflict Capacity to manage additional risk
LIHTC	8.3%	<ul style="list-style-type: none"> Further develop trading capabilities Automate delivery platform 	<ul style="list-style-type: none"> Value of credits impacted by corporate earnings volatility
Equity (Non-Tax)	62.5%	<ul style="list-style-type: none"> Expand customer base through new partnerships Automate delivery platform 	<ul style="list-style-type: none"> High competition reduces returns Market conditions prolong hold periods
Community Lending	73.2%	<ul style="list-style-type: none"> Expand product set Implement differentiated customer management strategy 	<ul style="list-style-type: none"> Capacity to manage new types of risk (e.g. AD&C)

**PROPRIETARY AND CONFIDENTIAL –
CONFIDENTIAL TREATMENT REQUESTED
BY FANNIE MAE**

Confidential - Internal Distribution

47

**Confidential Treatment
Requested By Fannie Mae**

FMSE 720746

What changes if we succeed – HCD Strategy

	2007	2011
Primary Competition	Conduits, Freddie, other LIHTC investors	Same plus investment banks, insurance companies, institutional equity investors, AD&C debt buyers
Customer Base Profile	DUS/Depository Lenders, LIHTC Fund Managers	Investment banks, regional small multifamily lenders, intermediaries, equity funds and other commercial real estate investment partners
Product Line / Business Line Mix	Permanent multifamily debt, low-income housing tax credits; emerging businesses in equity, AD&C, and public finance	Same plus for sale/for rent equity, mezzanine debt, bridge debt, product bundles across property lifecycle
Pricing strategy (including capital usage)	Bifurcated into OAS, G-fee; driven by regulatory capital	Unified pricing, driven by economic capital
Securitization versus portfolio usage	Portfolio is dominant execution	Portfolio; actively manage liquidity to ensure MF MBS remains viable; expand to new securitization structures and financial instruments to lay off risk, including Collateralized Debt Obligations, and Credit Default Swaps
Risk Layering and Sharing	Focus on risk sharing	Increased capability to price and manage risk allows us to acquire additional and new types of risk, holding it or transferring it as appropriate
Distribution and Customer service	DUS is major distribution channel and servicer	Multiple distribution channels to reflect expansion of permanent debt business, growth of new types of business
Technology Focus	Remediating by developing basic front-end systems to replace EUCs	Common business architecture with shared data repository
Operational Priorities	Adapt current systems for broader product sets, new types of partners and lines of business	Flexible/adaptable infrastructure and selective outsourcing
Key Value proposition – to lenders and partners	Reliable capital source based on big balance sheet, for narrow product range	Reliable, fast, and flexible capital source based on superior risk management

Capital Markets

Capital Markets plans single-digit income growth through 2011 and near double-digit adjusted rate of return on capital. The business will focus primarily on supporting the liquidity and price advantage of our MBS; purchasing mission-rich mortgage assets; and providing liquidity when the market needs it. The mortgage portfolio will grow opportunistically or shrink depending on market needs and prices. Should a market dislocation or other opportunity emerge, the Capital Markets group will respond profitably.

- **Market environment:** We expect that demand and competition for mortgage assets among investors will remain strong over the next three to five years, making the spreads between the cost of funding mortgage purchases and the yield from holding mortgages to remain tight. At the same time, these conditions may create additional opportunities to sell mortgage assets we own at attractive prices. All told, we do not expect optimal economic conditions for portfolio growth. However, demand for mortgage assets, especially overseas, will create good conditions for Fannie Mae to fund our portfolio and match our assets and liabilities.

**PROPRIETARY AND CONFIDENTIAL –
CONFIDENTIAL TREATMENT REQUESTED
BY FANNIE MAE**

Confidential - Internal Distribution

48

**Confidential Treatment
Requested By Fannie Mae**

FMSE 720747

- Strategy: Rather than pursue portfolio growth for its own sake, Capital Markets will work in tandem with Single-Family and HCD to support the company's overall strategy of expanding securitization, credit risk management and affordable housing impact. Capital Markets will focus on the following areas in particular:
 - Emphasize less liquid assets. We expect the greatest return to investment and the greatest mission benefit by supporting less liquid securities and those investments whose fundamental value is less recognized by the market. That includes multi-family loans and securities, commercial MBS backed by multifamily properties, non-traditional single family products such as 40-year, reverse mortgages, interest-first loans, "seconds," hybrid ARMs and specified pools of long-term fixed-rate mortgages.
 - Supporting the liquidity of the TBA MBS. A major priority for our balance sheet is to maintain equilibrium in TBA MBS trading in the market. To this end, we attempt to maintain an active volume of securities in secondary hands. We believe the free market is likely to operate effectively most of the time as the volume of lenders contributing to the MBS market remains large and diverse. Simultaneously, we expect REMIC and Mega production to remain healthy as it adds demand to MBS without detracting from overall MBS liquidity. We expect to use our balance sheet from time to time to support the demand for, and liquidity of, our MBS when market supply/demand conditions are unsettled for new or seasoned paper.
 - Investments in more credit-sensitive products. We believe there will be more opportunities for the portfolio to invest in credit-sensitive products, which would yield a significant premium above any expected losses. We also have unused risk-taking capacity relative to our required economic capital. In addition, we expect to be able to select a subset of credit-sensitive investments that should perform relatively well over their investment horizons. We believe this gradual shift supports our mission to provide investment capital to housing challenges.
 - Adoption of Fair Value Option. We cannot sell any significant volume of assets out of our holdings because we have declared the intent and ability to hold these assets. The adoption of the FAS 159 accounting standard in January 2008 will permit us to sell or re-securitize from a large pool of assets that are not currently available to us. This additional flexibility should enhance our profitability, our liquidity mission and our risk management to a modest extent.
 - Emphasis on structured products for financing. The market for GSE debt is increasingly moving toward a tailored model with frequent issuance of relatively small-denomination securities being issued to meet specific demands by small institutional investors. We expect this trend to continue over the next few years and plan to streamline our operations in order to be increasingly responsive to our debt investors.

**PROPRIETARY AND CONFIDENTIAL -
CONFIDENTIAL TREATMENT REQUESTED
BY FANNIE MAE**

Confidential - Internal Distribution

49

**Confidential Treatment
Requested By Fannie Mae**

FMSE 720748

What changes if we succeed – Capital Markets Strategy

	2007	2011
Size of Mortgage Portfolio	Determined by economics and accounting constraints	FAS 159 will reduce current constraints on sales
Unused capacity of economic capital	Considerable surplus economic capital	Increased Use of economic capital against credit sensitive assets
Funding source mix	Active funding tailored to investor demand	Extended investment in permitting new structures
Level of portfolio sales or resecuritizations	Highly limited currently due to accounting constraints	We expect to open up 10-20% of investment to possible sale
Balance Sheet asset mix	Largely concentrated in 30-year FRM	More illiquid securities & loans
Risk Layering , Management and Distribution	Mostly AAA assets including Fannie Mae MBS and private label securities purchased from the street	Greater use of subordinated tranches / RTF issued by Fannie Mae
Balance Sheet liability mix	Limited amount of structured product	Greater ability to use structured products
Key Value proposition -- to investors, lenders and partners	Strong returns with modest risk over 3-5 year horizon	Incremental credit risk on balance sheet with greater total returns
Key Value proposition internally -- to SFB and HCD	Support of price spread and purchase of loans	Increased purchase of credit sensitive loans and securities

Business Strategy Impact on Mission

- *We will “mainstream our mission” into our business and into the market with approaches that we can replicate and carry out in large scale.*
- *We will proudly re-enlarge our mission to include not only affordability, but middle incomes, liquidity and impact.*
- *As we focus on meeting tougher HUD goals, we also will target four key areas – urban/workforce housing; rural and Native American housing; rebuilding the Gulf Coast; and housing the homeless.*
- *We will integrate our mission-business strategies with our corporate giving.*

An important goal as we determined our *raison d’etre* as a company and chose our strategic path was to ensure our business would not only achieve our mission, but also transform how we achieve it. We want to “mainstream” our mission – that is, provide liquidity to low- and moderate-income segments of the market every day as part of our normal course of business. (Or, as I began stressing three years ago, “The mission is the business and the business is the mission.”)

Our strategic choice to emphasize credit risk management offers tremendous opportunities to achieve our affordable housing mission because, quite simply, underserved segments of the market would benefit as we bring our “fairest of them all” products, pricing and standards deeper down the credit scale. Expanding our service to these markets also offers tremendous business growth potential because these markets are both underserved (e.g., the

**PROPRIETARY AND CONFIDENTIAL –
CONFIDENTIAL TREATMENT REQUESTED
BY FANNIE MAE**

Confidential - Internal Distribution

50

**Confidential Treatment
Requested By Fannie Mae**

FMSE 720749

20-point gap between the minority homeownership rate and the national average), and the fastest-growing populations.

We are taking a more businesslike approach to our pursuing our mission in four ways:

1. Replicate, scale and grow. We will seek to replicate, expand in scale and grow one-off affordable housing initiatives and boutique products into full-fledged lines of businesses that serve communities and create value for shareholders. Our MyCommunityMortgage product is a good model. It began as a modest initiative to help our commercial bank customers meet their Community Reinvestment Act requirements. It evolved into our flagship affordable housing product now distributed nationally through our Desktop Underwriter (DU) system; in fact, in wake of the subprime market meltdown, demand has surged and we recently raised the price to more accurately balance risk and return. We will identify more places where Fannie Mae can mainstream mission activities into our business with approaches that are scalable and replicable.
2. Build controls, processes, metrics. The mission-related business will be subject to the same controls, processes and disciplines that we apply to our “normal” business. The work we have done over the past two years to “operationalize” our acquisition, development and construction lending program is a lesson learned for all our mission-related initiatives – do it right the first time, then go. We also will carry out our mission activities in way that provides measurable business value, and build mission-relevant metrics into our business activities and judge these activities based on the numbers.
3. Innovate quickly, nimbly. We will move quickly to pursue innovative approaches to affordable lending needs as they arise. For example, in response to the subprime market meltdown, in early 2007 we launched our HomeStay initiative to help struggling homeowners facing adjustable-rate payment shock refinance into safer products. Housing market shifts tend to hit underserved populations the hardest, so we will emphasize moving nimbly with our innovations.
4. Integrate business and mission. We will take steps to link and overlap the three business’ affordable housing initiatives with the company’s mission support functions, including our revamped Community Business Centers and Corporate Giving functions (described later in this section), and relationships with housing partners.

**PROPRIETARY AND CONFIDENTIAL –
CONFIDENTIAL TREATMENT REQUESTED
BY FANNIE MAE**

Confidential - Internal Distribution

51

**Confidential Treatment
Requested By Fannie Mae**

FMSE 720750

Integrating the Business and the Mission



Taking and managing more credit risk in our Single-Family, HCD, and Capital Markets businesses will give the company access to a wider array of mortgage assets that help our partners meet the needs of underserved populations – low- and moderate-income families, borrowers with non-traditional financial and credit histories, and communities that need investment capital for renewal. In particular:

- Single-Family will be able to offer more “affordability” mortgage products for borrowers with imperfect credit or non-standard employment and income records.
- HCD will grow businesses such as small multifamily lending that provides rental housing to lower income populations and its acquisition, development, and construction lending that is critical for community revitalization. It will also continue to expand its business with housing finance agencies to bring mortgage financing solutions to their targeted populations.
- Capital Markets’ focus on purchasing less liquid mortgage assets and credit-sensitive products will increase its contribution to our affordable housing business.

We plan to seek a reasonable rate of return on our “mission-rich” affordable housing business. We will not in all cases seek the highest rate of return, but we also will not subsidize our affordable housing business by accepting negative rates of return. In fact, because the affordable housing business tends to serve credit-challenged markets, proper risk-based pricing should provide a pricing premium and our effective credit risk management should reduce loss and expense. We will continue to utilize our experience and understanding of the multifamily housing market to serve the broadest possible spectrum of housing needs nationwide. Existing proofs of this concept include:

- Fannie Mae’s Low Income Housing Tax Credit business provides equity capital for the construction or rehabilitation of affordable housing targeted to households below 60 percent of area median income. Since 1987, this product has committed more than \$14.8 billion in capital serving more than 450,000 very low

**PROPRIETARY AND CONFIDENTIAL –
CONFIDENTIAL TREATMENT REQUESTED
BY FANNIE MAE**

Confidential - Internal Distribution

52

**Confidential Treatment
Requested By Fannie Mae**

FMSE 720751

income households while achieving returns which meet or exceed corporate return on equity targets.

- Fannie Mae's Modernization Express product provides capital to public housing authorities to renovate and recapitalize their public housing developments. Through this product we have invested more than \$143 million serving more than 13,400 very low-income households in publicly subsidized housing. This product is directed at families earning less than 30 percent of their area median income, and exceeds the company's required rate of return.

HUD goals get tougher

The HUD affordable housing goals are one public manifestation of our mission. Our strategy of expanding our credit risk appetite is critical in meeting these goals. For 2004-2008, the goals require Fannie Mae's acquisitions to finance a greater percentage of low-and moderate-income family mortgages than the proportion the market will produce. That is especially true as housing affordability – the combination of home prices, mortgage costs and incomes – has fallen. We had to absorb significant costs to meet the HUD purchase money subgoals in 2006, and we are struggling to meet the goals and subgoals in 2007. We will continue to pursue every reasonable opportunity to expand our purchases of goals-eligible mortgages.

The current housing goals rule will expire at the end of 2008. The strategy over the next year and a half is to work with our regulator to establish a more flexible goals regime that reflects market realities while still ensuring our market leadership in supporting affordable housing lending. We believe the new rule should set the housing goals levels based on the most current, best available market data and guide the regulator to adjust the goals levels in line with changing market conditions. Similarly, among the objectives for our engagement on the legislation before Congress is to enact new housing goal authorities that are consistent with the principle that the goals should reflect changing market opportunities for affordable housing lending.

Beyond HUD goals: Focused Investments on Particular Needs

In addition to providing liquidity and access to the broad housing finance market, Fannie Mae will seek to make investments in particular areas of housing need where the Company's specific skills and commitment can make an impact.

- Four target areas: Our strategic plan will focus on difficult and complex affordable housing challenges in four targeted areas: 1) Urban/workforce housing needs; 2) rural and Native American communities; 3) Gulf Coast rebuilding; and, 4) permanent, supportive housing for the homeless. This will require the company to invest in new infrastructure and products, as well as reorganize our Community Business Centers to focus on these areas (as described below).

**PROPRIETARY AND CONFIDENTIAL –
CONFIDENTIAL TREATMENT REQUESTED
BY FANNIE MAE**

Confidential - Internal Distribution

53

**Confidential Treatment
Requested By Fannie Mae**

FMSE 720752

- Above and beyond: Since the aftermath of Hurricane Katrina, we have invested over \$3.5 billion in the hard-hit Gulf Coast areas helping to restart lives, aiding evacuees, financing rebuilding, and leveraging our employees. That is in addition to our \$20 billion in normal business in that region to keep the market flowing. But in two years, we – and the rebuilding – have barely begun. In this area we are especially willing to take and manage additional credit risk, try new investment strategies and occasionally accept lower returns.

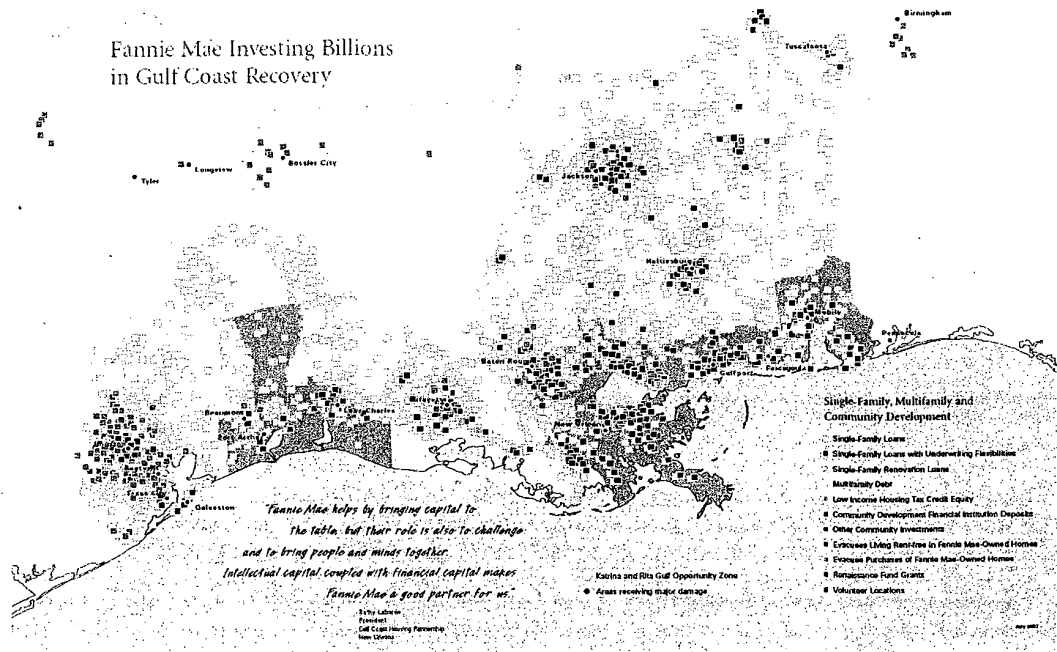

The company is refocusing the current 49 Community Business Centers from localized community development efforts to a centralized, higher-impact national approach to the four targeted mission activities (urban/workforce housing; rural and Native American communities; Gulf Coast rebuilding; and homelessness).

The Centers will be responsible for finding business opportunities for Single-Family, HCD and Capital Markets to address these four areas. The Centers will have a greater engagement directly with community partners, gathering local market intelligence for the company's competitive advantage and providing detailed analysis of potential opportunities and risks. In realigning the Centers, Fannie Mae will still maintain national coverage through 49 offices, and also, link the Centers with the Office of Community and Charitable Giving to provide more tools (e.g., investments and contributions). The goal is to have a more tangible impact on communities and work with local housing leaders nationwide to address specific community needs.

**PROPRIETARY AND CONFIDENTIAL –
CONFIDENTIAL TREATMENT REQUESTED
BY FANNIE MAE**

Confidential - Internal Distribution

54

**Confidential Treatment
Requested By Fannie Mae**

FMSE 720753

Integration of Corporate Giving

Our new Office of Community and Charitable Giving will help to achieve our mission. A major goal of bringing our philanthropic efforts into the company was to integrate them with our community investment strategies to have a greater impact on a broader scale – and to promote an even greater culture of service within the company. As we complete the transition of our giving efforts from the Fannie Mae Foundation, the company plans to make \$42 million in contributions this year while the foundation plans to provide \$28 million.

The community giving office will focus on 1) supporting housing and community development initiatives nationwide; 2) helping to prevent and end homelessness; and 3) helping to build thriving communities in Washington, D.C. The office will leverage all of the resources of Fannie Mae – financial capital; seed capital (grants); human capital (volunteerism); and intellectual capital – and collaborate with the business units and support functions of the company, such as Human Resources.

A recent example of this work can be found in our response to the subprime market turmoil. As part of Fannie Mae's effort to assist, we provided \$5 million in grants to NeighborWorks America and the Homeownership Preservation Foundation to increase public awareness of foreclosure challenges, expand counseling, build the capacity of local coalitions, and enhance the use of technology in counseling. The goal of the grants is to provide counseling to more than 90,000 homeowners at risk of foreclosure, with nearly 40,000 ultimately avoiding foreclosure.

Another important element of the Office of Community and Charitable Giving will be targeting resources to build capacity among our housing development partners to both strengthen their work and its impact on local communities. For instance, the Office of Community and Charitable Giving is currently working with our Community Lending team to develop a comprehensive strategy that presents one voice to the non-profit community. In recent strategic discussions with the Local Initiatives Support Corporation (LISC), we presented an outline that includes:

- a line of credit debt facility to help fund specific community development projects through our Financial Intermediaries Channel;
- training with our Public Entities Channel to address public housing rehabilitation strategies;
- tax credit investments to spur supportive housing development for the homeless in select markets;
- sharing of intellectual capital to support Rural 515 manufactured housing financing; and
- grant money to support both forums convened by LISC to address affordable housing challenges and operating support to help LISC scale its operations behind these business opportunities.

Our new strategy ties our grant making activities to business opportunities wherever possible, and in its early stages, has been well-received by the non-profit community.

**PROPRIETARY AND CONFIDENTIAL –
CONFIDENTIAL TREATMENT REQUESTED
BY FANNIE MAE**

Confidential - Internal Distribution

55

**Confidential Treatment
Requested By Fannie Mae**

FMSE 720754

Taking Action – Execution Drivers

Our business and mission will be powered by a corporate-wide strategy for execution. Our strategic plan has a number of dependent variables in order to generate results. In some cases, systems and processes need to be revamped. In others it is a simple matter of shoring up talent, organizational structure, controls, or policies. In all cases, however, the businesses will chart their path to execution so we can set our priorities across the company and make the appropriate trade-offs in our resource allocation plan.

For example, take our strategy of adding credit-sensitive assets to the balance sheet. We currently have capacity to grow in this direction, but our vision of becoming a nimble and effective market player in this space will require us to cover many bases over a period of time as you see in the exhibit on the next page.

Execution Strategy to be nimble and effective

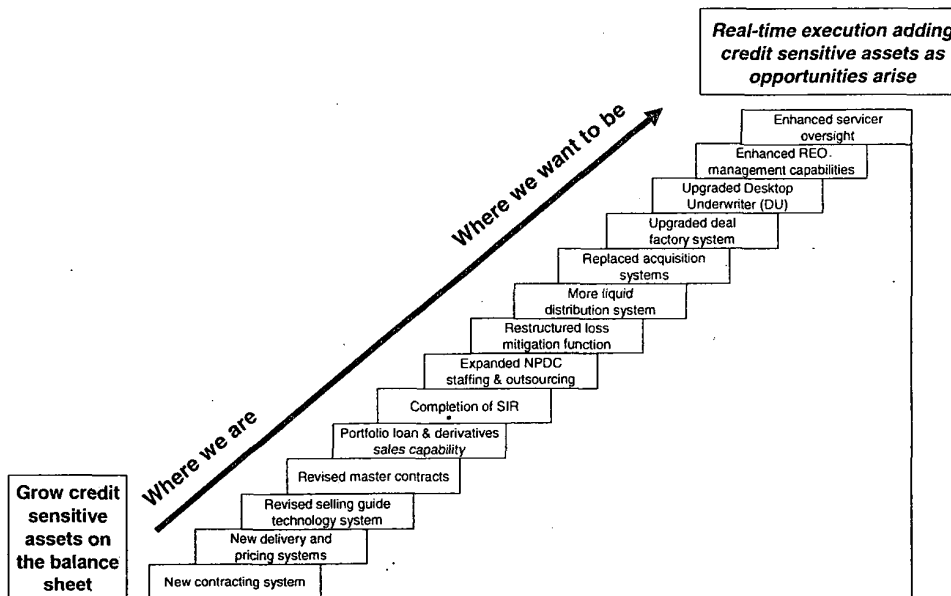

Our listening tour with customers pointed to the need to improve in how and when we execute. Some said in substance “Stop listening and start delivering.” Others said “Provide solutions now ... It’s nice that Fannie Mae is listening, but in this challenging market, customers are looking to Fannie Mae for answers not questions.”

**PROPRIETARY AND CONFIDENTIAL –
CONFIDENTIAL TREATMENT REQUESTED
BY FANNIE MAE**

Confidential - Internal Distribution.

56

**Confidential Treatment
Requested By Fannie Mae**

FMSE 720755

Over the next 90 days following Board input, this strategic plan will be joined by an execution plan to deliver on approved priorities throughout all organizational functions including:

- Operations and Information
- Human Resources
- Risk
- Financial Management
- Legal and Compliance
- Government and Industry Relations
- Audit

All levels of the organization will align themselves with what those priorities are, what resources will be deployed, what our timelines are, and where the accountability rests. We will shift, adapt, and redirect our efforts as needed by unique windows of opportunity or challenges. Our strategy and our execution plan will aim to be responsive to our customers, investors, and partners in real time. The execution will need to be as good as our strategy – if not better.

Summary: Section IV

- *Maintain MBS positioning*
 - *Liquidity and transparency*
 - *Portfolio support*
 - *Best execution*
- *Expand credit securitization/investment capabilities*
 - *New product segments plus Risk Transformation Facility*
 - *Single-Family: front and back end capability*
 - *HCD: extend beyond Low Income Housing Tax Credits and DUS multifamily lender partners*
 - *Capital Markets: broader asset mix*
- *Mainstream the mission*
 - *Redefine and integrate*
 - *Restructure Community Business Centers*
 - *Office of Community and Charitable Giving in supportive role*
- *Drive execution*
 - *Affirm priorities*
 - *Human Resources and culture implications*

**PROPRIETARY AND CONFIDENTIAL –
CONFIDENTIAL TREATMENT REQUESTED
BY FANNIE MAE**

Confidential - Internal Distribution

57

**Confidential Treatment
Requested By Fannie Mae**

FMSE 720756

**How We'll Measure Success –
New Financial Measures & Metrics**

**Confidential Treatment
Requested By Fannie Mae**

FMSE 720757

Section V: How We Will Measure Success – New Financial Measures and Metrics

- *Disclosures and new financial measures will reflect the economic drivers of the businesses and create a common language for both performance management and performance measurement.*
- *These measures, combined with a two-tiered capital distribution strategy, will provide a clear picture of value creation over time.*
- *The new performance measures focus on three key elements:*
 - *Reporting segment results for Single-Family, HCD and Capital Markets*
 - *Disclosing a new non-GAAP measure called “Adjusted Net Income”*
 - *Providing a suite of financial disclosures for each segment*

This plan introduces new measures of financial performance and more expansive disclosures of business segment results. At their root, these new measures are designed to provide a reasonable picture of how the Company is performing and highlight the key drivers affecting the business. Also, these measures are aligned with the metrics we use to manage the business – which links the numbers and management activities.

Fundamentally, two key numbers drive our value: The earnings multiple paid for sustainable GAAP earnings from the guaranty fee business; and the book multiple attached to the net balance sheet assets. Apple-to-apple, the guaranty fee multiple is likely to be higher than that for Capital Markets.

Business Segment Results

The plan is focused on three business segments — Single-Family, HCD, and Capital Markets — which is consistent with how we manage the business. The numbers we use to measure our own internal performance will be the same as those used to report the business; key metrics that are important to the business are also reported as part of the plan. This approach communicates information about the company in a consistent manner and it should help us focus on and deliver shareholder value as we all begin to speak a common measurement language.

Segment reporting also delineates the different businesses drivers that exist within the company. In particular, the business drivers behind Single-Family and HCD businesses are meaningfully different from the business drivers supporting the Capital Markets business. Segment reporting allows an insightful view into the revenues, expenses, adjusted net income and related metrics associated with each of our business segments.

A New Measure

There is not one standard measure that comprehensively and accurately captures the operating results of Fannie Mae. GAAP does a good job at capturing the results in the Single-Family and HCD businesses and, in our judgment, best reflects how successful (or not) we have been at managing those businesses.

**PROPRIETARY AND CONFIDENTIAL –
CONFIDENTIAL TREATMENT REQUESTED
BY FANNIE MAE**

Confidential - Internal Distribution

58

**Confidential Treatment
Requested By Fannie Mae**

FMSE 720758

However, GAAP does not produce a reasonable measure of Capital Markets' performance, principally because it applies different accounting to assets, liabilities and derivatives. In addition, GAAP recognizes net interest income of certain matched asset-and-liability transactions in an uneven way, frequently accelerating net interest income into earlier periods.

We believe changes in the fair value of net assets after an adjustment for changes in spread are a good measure for Capital Markets' annual performance. Essentially, this adjusted fair-value measure reflects a level net interest income (spread), which represents economic earnings over the life of the portfolio. We believe it best reflects our strategy of being a long-cycle investor in mortgages, and removes the impact of periodic and temporary changes in market value. Importantly, this measure is used to manage the business and also is used to describe the capital markets activity of our primary competitor, Freddie Mac.

Fair value does not do a good job reflecting the operating performance of Single-Family and HCD, principally because the credit characteristics of our book of business are hard to measure in a reliable manner. Fair value also is not reflective of the business practices of our Single-Family and HCD businesses, as we are a "buy-and-hold" issuer of guarantees, not a trader of guarantees.

For purposes of this plan, we propose a measure, *Adjusted Net Income*, which combines GAAP results for the Single-Family and HCD businesses and fair value adjusted for changes in spread for the Capital Markets business. We believe Adjusted Net Income is the best measure for capturing the performance of the Company.

These non-GAAP metrics will supplement, not replace, GAAP. In all cases, non-GAAP measures will be reconciled to GAAP. In the case of adjusted fair value, total fair value, which includes the effect of spreads, will be provided as well. These disclosures will be completely consistent with SEC rules that contemplate some companies do in fact manage their business for results that differ from GAAP. Such is the case with Fannie Mae's Capital Markets business.

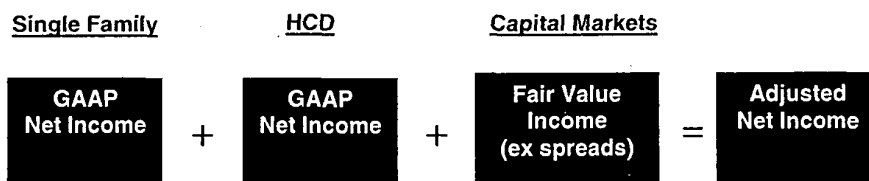

Suite of Financial Disclosures

In addition to this new measure, a suite of financial disclosures will be provided on our three business segments. These disclosures will focus on the key drivers affecting the business and are consistent with disclosures of our competitors in similar industries. These disclosures can be summarized as follows:

**PROPRIETARY AND CONFIDENTIAL –
CONFIDENTIAL TREATMENT REQUESTED
BY FANNIE MAE**

Confidential - Internal Distribution

59

**Confidential Treatment
Requested By Fannie Mae**

FMSE 720759

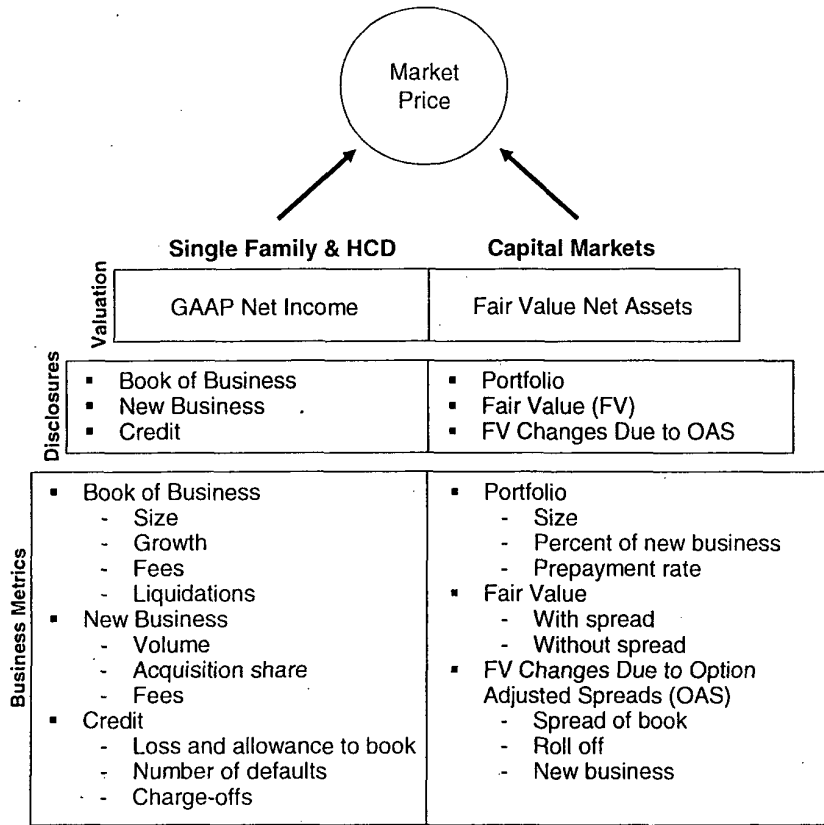

Combination of New Measures and Metrics. Taken together, the segment focus, GAAP and non-GAAP measures, and supplemental financial disclosures of key business drivers should provide a clear picture of economic results and help investors and other stakeholders answer key questions about our operating performance and value.

**PROPRIETARY AND CONFIDENTIAL –
CONFIDENTIAL TREATMENT REQUESTED
BY FANNIE MAE**

Confidential - Internal Distribution

60

**Confidential Treatment
Requested By Fannie Mae**

FMSE 720760

Financial Overview

- *Growth across all three business segments.*
- *18% annual growth rate of quarterly cash dividends.*
- *Mix of net income shifts to higher-multiple earnings from Single-Family and HCD.*

This plan is the result of a bottom-up process involving the business segment and finance organizations. The plan is focused around three key drivers that provide strong financial results over the plan period — high single-digit revenue growth, aggressive cost containment, and active distribution of excess capital. The plan assumes that OFHEO lifts the portfolio cap after we are a current filer and have completed all outstanding remediation requirements. We believe the plan is challenging, but achievable. The key elements of the plan are as follows:

- 10 percent annual revenue growth through 2011, from \$10.5 billion to \$15.5 billion, with growth across all of our business segments.
- 13 percent annual adjusted net income growth through 2011, from \$4.5 billion to \$7.3 billion, driven by revenue growth and cost containment.
- 14 percent annual adjusted EPS growth through 2011, from \$4.39 to \$7.49, driven by adjusted net income growth and stock repurchases.
- 18 percent average quarterly cash dividend growth annually through 2011, from 47 cents to 93 cents, which should place Fannie Mae in the top quartile for dividend returns.
- Adjusted Return on Average Equity (ROE) in mid to high teens, growing from an annual rate of 14 percent in 2008 to 17 percent in 2011.
- \$3 billion of shares repurchased through 2011.

In addition, over the plan period the mix of earnings shifts toward the higher-valued net income generated from the Single-Family and HCD businesses. In particular, in 2007 about 60 percent of Fannie Mae's adjusted net income is from Single-Family and HCD, and 40 percent is from Capital Markets. By the end of the plan, 70 percent of the adjusted net income is from Single-Family and HCD, and 30 percent is from Capital Markets. Unless otherwise noted, income numbers exclude non-recurring administrative expenses, catch-up/get current, and restructuring costs.

**PROPRIETARY AND CONFIDENTIAL -
CONFIDENTIAL TREATMENT REQUESTED
BY FANNIE MAE**

Confidential - Internal Distribution

61

**Confidential Treatment
Requested By Fannie Mae**

FMSE 720761

Corporate Financial Outlook 2007-2011

\$B, unless noted	2007	2008	2009	2010	2011	07-11 CAGR
Adjusted Revenue						
Single Family	\$ 7.0	\$ 7.8	\$ 8.8	\$ 9.6	\$ 10.7	11.1%
Housing & Community Development	1.2	1.4	1.6	1.8	2.0	12.6%
Capital Markets	3.1	3.1	3.2	3.5	3.8	5.7%
Elimination	(0.8)	(0.9)	(1.0)	(1.0)	(1.0)	
Total Company	\$ 10.5	\$ 11.5	\$ 12.6	\$ 13.9	\$ 15.5	10.1%
Adjusted Net Income (1)						
Single Family	\$ 2.2	\$ 2.8	\$ 3.4	\$ 3.7	\$ 4.2	17.3%
Housing & Community Development	0.4	0.6	0.7	0.8	0.9	18.8%
Capital Markets	1.9	1.8	1.9	2.0	2.2	4.9%
Total Company	\$ 4.5	\$ 5.2	\$ 5.9	\$ 6.5	\$ 7.3	12.9%
Financial Metrics						
Adjusted EPS	\$ 4.39	\$ 5.18	\$ 6.01	\$ 6.66	\$ 7.49	14.3%
Quarterly Cash Dividends	\$ 0.47	\$ 0.55	\$ 0.73	\$ 0.81	\$ 0.93	18.2%
Share Repurchases (\$B)		\$1.0	\$0.4	\$0.6	\$1.1	
Adjusted ROE	12.2%	14.1%	15.5%	16.2%	17.2%	
GAAP ROE	12.6%	13.2%	13.9%	14.8%	15.2%	

(1) Excluding non-recurring admin expense / Catch-Up / Get Current and restructuring costs

\$B	2007	2008	2009	2010	2011	07-11 CAGR
Adjusted NI to Common						
Single Family	\$ 2.0	\$ 2.6	\$ 3.2	\$ 3.5	\$ 3.9	18.4%
HCD	0.4	0.5	0.7	0.8	0.9	19.0%
Capital Markets	1.9	1.8	1.9	2.0	2.2	4.8%
Total Adjusted NI	\$ 4.3	\$ 5.0	\$ 5.7	\$ 6.3	\$ 7.0	13.1%
Allocated Common Capital (excluding OCI)						
Single Family	\$ 12.3	\$ 13.0	\$ 13.9	\$ 14.7	\$ 15.1	5.2%
HCD	0.8	0.9	1.0	1.1	1.2	10.3%
Capital Markets	20.8	19.9	20.9	22.0	23.1	2.7%
Cushions / Excess*	1.7	2.0	2.0	2.0	2.0	
Total Allocated Capital	\$ 35.7	\$ 35.8	\$ 37.8	\$ 39.9	\$ 41.5	3.9%
Returns on Allocated Capital						
Single Family	16.1%	20.6%	23.5%	24.4%	26.2%	
HCD	52.7%	62.1%	68.3%	70.3%	71.5%	
Capital Markets	9.6%	9.2%	9.2%	9.5%	9.9%	
Adjusted ROC	12.2%	14.1%	15.5%	16.2%	17.2%	

* Excludes Derivative VAR, which is attributed to Capital Markets

Confidential - Internal Distribution
**PROPRIETARY AND CONFIDENTIAL -
 CONFIDENTIAL TREATMENT REQUESTED
 BY FANNIE MAE**

Confidential Treatment
 Requested By Fannie Mae

FMSE 720762

Single-Family Earnings Outlook and Key Metrics

- The Single-Family business outlook is for 17 percent annual adjusted net income growth, from \$2.2 billion in 2007 to \$4.2 billion in 2011, driven by double-digit revenue growth and controlled administrative costs and credit expenses.
- Revenue grows 11 percent annually, from \$7.0 billion in 2007 to \$10.7 billion in 2011, because of increases in guaranty fee (G-Fee) income. G-Fee income growth is driven by increased volume and changes in mix: our book grows at rates that exceed mortgage debt outstanding (MDO) growth while the G-Fee rate increases as our mix of business includes higher-yielding Alt-A and subprime product.
- New business volumes are expected to track the market — shrinking in 2008 and 2009 as refinancing activity slows, but rising thereafter. Our share, about 30 percent of total origination volume, is expected to remain stable.
- Day One Losses — the accounting treatment on assets for which we pay a premium over market price — reach their highest levels in 2007 at \$1 billion, reflecting declining home prices and competitive pricing pressures. After 2008, those losses level off at approximately \$0.5 billion, as home prices increase and pricing returns to normal levels.
- Credit and credit-enhancement expenses increase because of higher-risk products in our book, partially offset by reduced credit costs related to our traditional products as home prices rebound at the levels assumed in our outlook. As indicated in the summary part of this plan, it is likely we will assume more credit risk. This would result in lower credit enhancement expense than indicated in the chart below, which in turn would lead to higher credit expenses.
- Administrative costs decline in 2008, reflecting improved operating efficiencies and the effect of actions undertaken in 2007.
- Returns on equity grow from 16 percent in 2007 to 26 percent by 2011, driving significant value creation over the plan period. The returns highlight the benefits of scale.

Single-Family Earnings Outlook 2007-2011

\$B	2007	2008	2009	2010	2011	07-11 CAGR
Net interest income	\$ 1.2	\$ 1.1	\$ 1.2	\$ 1.2	\$ 1.3	3.0%
Guaranty fees (incl. notional)	5.6	6.5	7.4	8.1	9.1	13.1%
Fee and other income	0.3	0.3	0.3	0.3	0.3	-1.7%
Revenue	\$ 7.0	\$ 7.8	\$ 8.8	\$ 9.6	\$ 10.7	11.1%
Investment Gain/(Loss)	0.2	0.2	0.2	0.2	0.2	0.0%
Day 1 Losses	(1.0)	(0.7)	(0.5)	(0.5)	(0.5)	N/A
Credit Expenses	(1.3)	(1.4)	(1.5)	(1.6)	(1.7)	7.6%
Credit enhancement/Other Expenses	(0.4)	(0.5)	(0.7)	(0.8)	(0.9)	25.0%
Operating Admin Expenses	(1.2)	(1.1)	(1.1)	(1.1)	(1.2)	0.3%
Total Expenses	\$ (3.7)	\$ (3.5)	\$ (3.6)	\$ (3.9)	\$ (4.2)	3.2%
Pre-tax income	3.3	4.3	5.2	5.7	6.5	18.3%
Taxes	(1.1)	(1.5)	(1.8)	(2.0)	(2.3)	20.2%
NI Excl. Non-Recurring Admin Expenses	\$ 2.2	\$ 2.8	\$ 3.4	\$ 3.7	\$ 4.2	17.3%

(1) Excluding non-recurring admin expense / Catch-Up / Get Current and restructuring costs

**PROPRIETARY AND CONFIDENTIAL –
CONFIDENTIAL TREATMENT REQUESTED
BY FANNIE MAE**

Confidential - Internal Distribution

63

**Confidential Treatment
Requested By Fannie Mae**

FMSE 720763

Key Single-Family Metrics

SF Book of Business (\$T) and Guaranty Fee (bps)

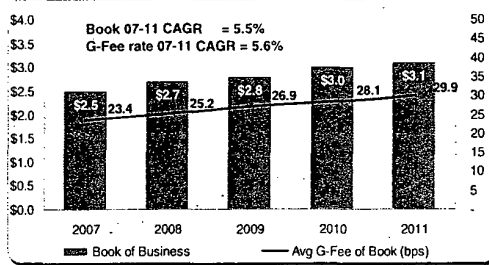

SF Credit Expenses (\$B) and Cr Exp to Avg Book Ratio (bps)

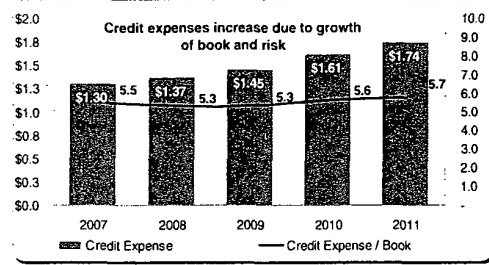

Book of Business Growth

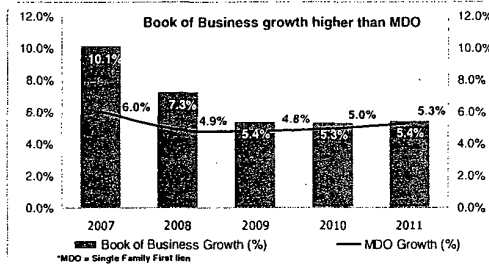

New Business Volume (\$B)

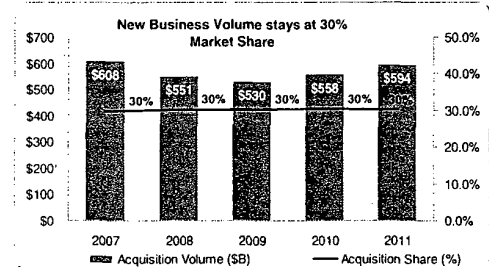

PROPRIETARY AND CONFIDENTIAL -
CONFIDENTIAL TREATMENT REQUESTED
BY FANNIE MAE

Confidential - Internal Distribution

64

Confidential Treatment
Requested By Fannie Mae

FMSE 720764

HCD Earnings Outlook and Key Metrics

- HCD's adjusted net income grows almost 19 percent annually, from \$0.4 billion in 2007 to \$0.9 billion in 2011, driven by annual revenue growth of 13 percent and costs containment.
- Revenue growth is fueled by our book of business rising at 8 percent annually, from \$141 billion in 2007 to \$195 billion in 2011. Growth is attributable to the multifamily business growing in excess of MDO, and from new HCD initiatives such as small loans and acquisition, development and construction (AD&C) lending in Community Lending.
- The tax-advantaged LIHTC business increases from \$1.5 billion in volume in 2007 to generating \$2 billion or more of volume annually from 2008 through 2011, which benefits Fannie Mae's effective tax rate.
- Credit and operating expenses remain essentially flat over the plan period.
- Return on equity is extraordinarily high, growing to over 70 percent as the Company scales up its investment in the highly capital-efficient business of multi-family lending combined with a high degree of tax benefits.

HCD Earnings Outlook 2007-2011

\$B	2007	2008	2009	2010	2011	07-11 CAGR
Debt Revenue	\$ 0.6	\$ 0.7	\$ 0.8	\$ 1.0	\$ 0.9	10.8%
Equity Revenue	0.6	0.7	0.8	0.9	1.1	14.4%
Revenue	\$ 1.2	\$ 1.4	\$ 1.6	\$ 1.8	\$ 2.0	12.6%
Credit expenses	(0.0)	(0.1)	(0.1)	(0.1)	(0.1)	18.7%
Credit enhancement	(0.1)	(0.1)	(0.1)	(0.1)	(0.1)	0.0%
Ongoing Administrative Expenses	(0.5)	(0.5)	(0.5)	(0.5)	(0.5)	0.9%
Total Expenses	\$ (0.6)	\$ (0.6)	\$ (0.6)	\$ (0.6)	\$ (0.7)	2.4%
Pre-tax income	0.6	0.9	1.0	1.2	1.3	20.0%
Taxes	(0.2)	(0.3)	(0.4)	(0.4)	(0.5)	22.5%
NI Excl. Non-Recurring Admin Expenses	\$ 0.4	\$ 0.6	\$ 0.7	\$ 0.8	\$ 0.9	18.8%

(1) Excluding non-recurring admin expense / Catch-Up / Get Current and restructuring costs

**PROPRIETARY AND CONFIDENTIAL -
CONFIDENTIAL TREATMENT REQUESTED
BY FANNIE MAE**

Confidential - Internal Distribution

65

**Confidential Treatment
Requested By Fannie Mae**

FMSE 720765

Key HCD Metrics

HCD Book of Business (\$B) & MF Guaranty Fees (bps)

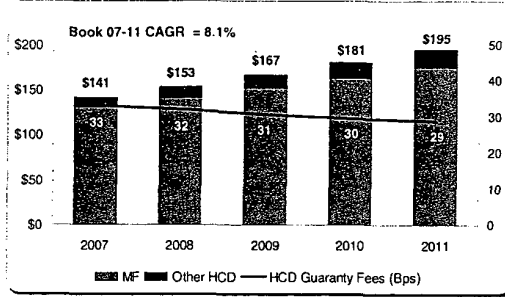

LIHTC Volumes per Year (\$B)

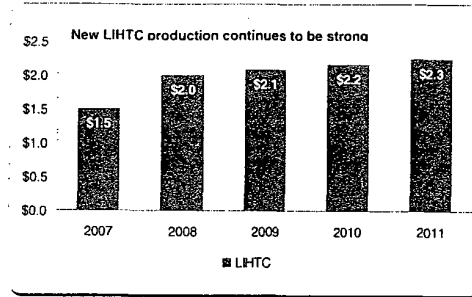

MF Book of Business Growth vs. MDO Growth

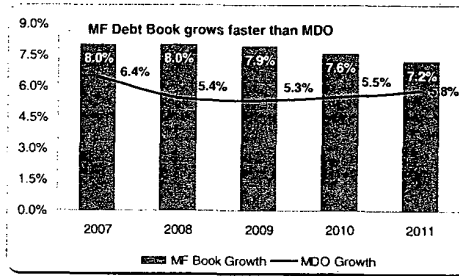

**PROPRIETARY AND CONFIDENTIAL -
CONFIDENTIAL TREATMENT REQUESTED
BY FANNIE MAE**

Confidential - Internal Distribution

66

**Confidential Treatment
Requested By Fannie Mae**

FMSE 720766

Capital Market Fair Value Earnings Outlook and Key Metrics

- Capital Markets fair value net income grows almost 5 percent annually, from \$1.9 billion in 2007 to \$2.2 billion in 2011, driven by increases in average option-adjusted spreads and modest portfolio growth.
- Fair value revenue grows almost 6 percent annually, from \$3.1 billion in 2007 to \$3.8 billion in 2011, as option-adjusted spreads grow from over 25 bps to 28 bps over the plan period. Portfolio grows from about \$700 billion in 2007 to more than \$800 billion in 2011. We are assuming the current cap on the portfolio is lifted or revised to allow for this growth.
- Costs remain relatively flat over the plan period.
- Return on equity will be in the 9 percent range per year throughout the plan period.
- We have not assumed any “opportunity” events, though historically these events have occurred.

Capital Markets Earnings Outlook 2007-2011

\$B	2007	2008	2009	2010	2011	07-11 CAGR
Portfolio and LIP Fair Value Income	\$ 3.2	\$ 3.2	\$ 3.4	\$ 3.7	\$ 4.0	6.3%
Market Risk Fair Value Return	0.1	0.1	0.1	0.1	0.1	3.7%
Less Capital Charge	(0.5)	(0.5)	(0.5)	(0.6)	(0.6)	5.8%
Total Fair Value Net Interest Income	\$ 2.8	\$ 2.8	\$ 3.0	\$ 3.2	\$ 3.6	6.3%
Fee & Other Income	0.3	0.2	0.2	0.2	0.2	6.3%
Total Fair Value Revenue	\$ 3.1	\$ 3.1	\$ 3.2	\$ 3.5	\$ 3.8	5.7%
Operating Administrative Expenses	(0.5)	(0.4)	(0.4)	(0.5)	(0.5)	1.1%
Pre-Tax Income	2.6	2.6	2.7	3.0	3.3	6.5%
Taxes	(0.7)	(0.8)	(0.8)	(0.9)	(1.1)	10.4%
FV NI Excl. Non-Recurring Admin. Expenses	\$ 1.9	\$ 1.8	\$ 1.9	\$ 2.0	\$ 2.2	4.9%

(1) Excluding non-recurring admin expense / Catch-Up / Get Current and restructuring costs

Key Capital Markets Metrics

CM Portfolio Size (\$B) and Annual Growth (%)

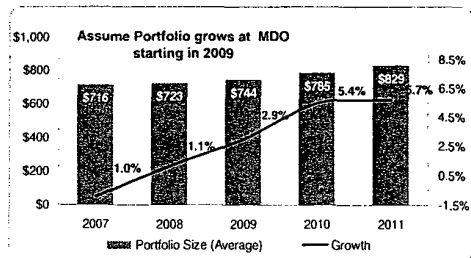

Option Adjusted Spread (bps)

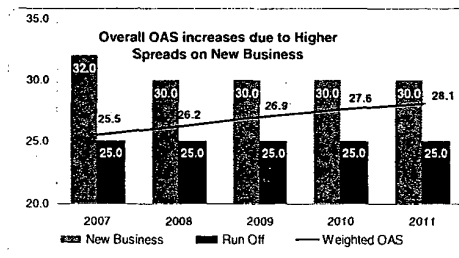

PROPRIETARY AND CONFIDENTIAL -
CONFIDENTIAL TREATMENT REQUESTED
BY FANNIE MAE

Confidential - Internal Distribution

67

Confidential Treatment
Requested By Fannie Mae

FMSE 720767

Administrative Expenses

- Costs before non-recurring expenses reduced to \$2 billion in 2008, remain flat in 2009, and then grow slightly in 2010-2011.
- Expenses will be actively managed with a focus on headcount, our professional services and more modest employee benefits.

\$B, unless noted	2007	2008	2009	2010	2011
Single Family	\$ 1.2	\$ 1.1	\$ 1.1	\$ 1.1	\$ 1.2
HCD	0.5	0.5	0.5	0.5	0.5
Capital Markets	0.5	0.4	0.4	0.5	0.5
Total Before Non-Recurring Admin Expense	\$ 2.1	\$ 2.0	\$ 2.0	\$ 2.1	\$ 2.2
Catch-Up / Get Current (CU/GC)	0.7	0.2	\$ -	\$ -	\$ -
Restructuring	0.1	0.1	\$ -	\$ -	\$ -
Total	\$ 2.9	\$ 2.3	\$ 2.0	\$ 2.1	\$ 2.2
Growth Before Non-Recurring Admin Expense	3%	-5%	0%	4%	4%
Efficiency Ratio Before Non-Recurring Admin Expense	20%	17%	16%	15%	14%

Sensitivities

	2008 EPS Impact	
	Downsides	Upsides
Corporate		
Admin Expense Reductions Miss Target by \$100m	(\$0.07)	
Single Family		
Subprime Volume 30% lower than expected	(\$0.02)	
Credit loss severity per loan increases 10%	(\$0.13)	
Elimination of Non-charter CE for 2008 Acquisitions		\$0.10
HCD		
Delayed ramp-up of Community Lending initiatives (2008 vs 2007)	(\$0.01)	
New Divisional Initiatives 50% lower than expected	(\$0.02)	
Capital Markets		
OAS on New Business Reduced 5bps to -25bps	(\$0.06)	
Portfolio Growth at MDO in 2008		\$0.04
Total Company Impact	(\$0.31)	\$0.14
Total Company Adjusted EPS	\$5.18	\$5.18
Sensitivity as % of Total	-6%	3%

**PROPRIETARY AND CONFIDENTIAL -
CONFIDENTIAL TREATMENT REQUESTED
BY FANNIE MAE**

Confidential - Internal Distribution

68

**Confidential Treatment
Requested By Fannie Mae**

FMSE 720768

This plan has three key assumptions, any of which could change projections if circumstances change. However, we believe, overall, that the risks and sensitivities are relatively balanced. The three assumptions are:

- The company is able to grow its credit risk prudently, that it can hire and retain the expertise necessary to assess the credit risk, and be adequately compensated for taking the risk.
- Supervisory and legislative bodies will accept the notion of additional credit risk at current capital levels — and not change the rules of the road.
- The market will remain broad enough to support significant investment from Capital Markets at acceptable spreads.

**PROPRIETARY AND CONFIDENTIAL –
CONFIDENTIAL TREATMENT REQUESTED
BY FANNIE MAE**

Confidential - Internal Distribution

69

**Confidential Treatment
Requested By Fannie Mae**

FMSE 720769

Capital Distribution Strategy

Our capital distribution strategy results in significant increases in our cash dividend, as well as the initiation of a multi-billion-dollar share repurchase program. The two tiers of the strategy are related, with the intent to secure a steady stream of income for cash dividends while using excess capital from Capital Markets opportunistically in the form of share repurchases or, when necessary, to support the dividend.

Cash Dividend

We believe the steady and relatively predictable earnings of the Single-Family and HCD businesses should be used as a guide to help determine the level of cash dividends paid by the Company. This plan assumes 65 to 81 percent of Single-Family and HCD earnings will be paid out in cash, which results in average quarterly cash dividends growing from 47 cents in 2007 to 93 cents in 2011. We anticipate that our dividend payout ratio and dividend yield will be competitive with other select financial institutions.

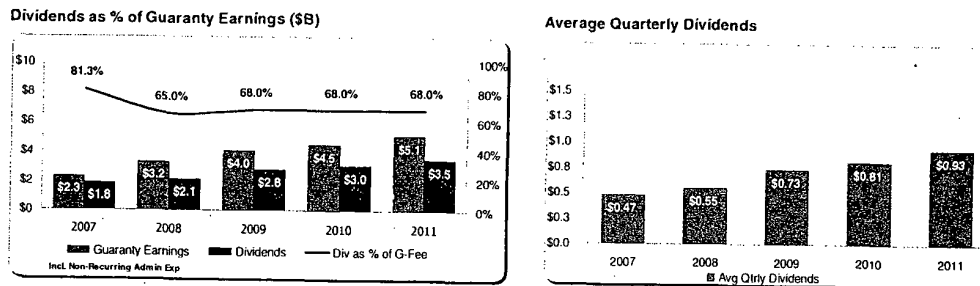

Share Repurchase

The capital needs of the Capital Markets business are more difficult to predict as the portfolio could grow or contract depending on market conditions. Separately, we look to lower our marginal cost of equity capital by approximately 4 percent by replacing common equity with preferred stock to a practical limit of 20 to 25 percent of preferred stock outstanding to total core capital. The plan assumes excess capital, including excess capital generated by the Capital Markets business and through incremental preferred stock issuance, is distributed in the form of a flexible share repurchase program. Over the plan period, we have assumed about \$3 billion of share repurchases as follows:

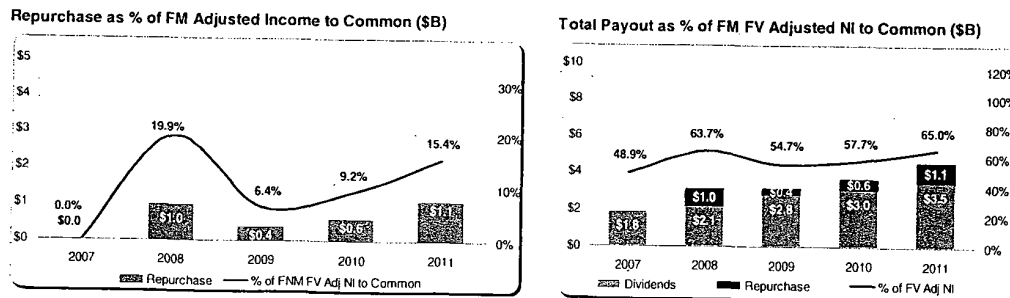

Confidential - Internal Distribution
**PROPRIETARY AND CONFIDENTIAL -
 CONFIDENTIAL TREATMENT REQUESTED
 BY FANNIE MAE**

Confidential Treatment
 Requested By Fannie Mae

FMSE 720770

Summary: Section V

- *Lead with GAAP*
- *Adjusted Net Income combines guaranty fee GAAP with portfolio change in fair value as key measure*
- *Plan outlook:*
 - *Revenues: 10.1 percent CAGR, reaching \$15.5 billion in 2011*
 - *Adjusted Net Income: 12.9 percent CAGR, reaching \$7.3 billion in 2011*
 - *Earnings Per Share: 14.3 percent CAGR, reaching \$7.49 in 2011*
 - *Return on Equity: Growing from 12.2 percent in 2007 to 17.2 percent in 2011*
- *Capital distribution competitive*
 - *Dividend to 93 cents*
 - *Share repurchased from Capital Markets*

**PROPRIETARY AND CONFIDENTIAL -
CONFIDENTIAL TREATMENT REQUESTED
BY FANNIE MAE**

Confidential - Internal Distribution

71

**Confidential Treatment
Requested By Fannie Mae**

FMSE 720771

Reintroduction of Fannie Mae -
Writing the Next Chapter

**Confidential Treatment
Requested By Fannie Mae**

FMSE 720772

Section VI: The Reintroduction of Fannie Mae

- *Fannie Mae will begin this Fall to reemerge and reintroduce ourselves as a company.*
- *We will reflect our new management, new approach to the market, new value proposition and new “look, feel, tone and manner” consistent with our role in the market.*
- *We recognize and embrace our role as a B2B business – we are here to serve our customers and partners who serve homeowners.*
- *We will let our achievements – not hype – speak for us.*

The final step in our business strategy is to “reintroduce” the company as we complete the remediation phase at Fannie Mae, become a current financial filer and pursue our new business strategy. The guiding principle of this “reintroduction” of Fannie Mae is alignment: aligning the strategy, the mission and the metrics with one single, consistent message. As Fannie Mae returns to the marketplace with current numbers, new management and a new strategy, new impressions of the company will be formed that will last for years to come. I believe we will get only one chance to make that first impression. This is our chance, and it is crucial that we get it right – critical, because the tone and manner of our message has for many years been an outsized part of the story of Fannie Mae.

It is vital, as we reintroduce the company, to recognize that not only will what we say be scrutinized, but how we say it. Tone and manner matter, because they reinforce message and numbers.

Since 2005, our actions, tone and manner have been closely aligned with our core message: “Change, Progress, More to Do.” The message reflected a set of values that people could understand -- values such as humility, hard work, and forthrightness. The message reflected a reality, a set of facts – intense regulatory and legal scrutiny combined with an extensive and costly accounting restatement – that the company was grappling with on a daily basis. Inherent in the message was an acknowledgement that the way Fannie Mae conducted itself in the past had to **change**, that it was committed to making **progress** on the many issues confronting it, and that it was forthright enough to admit it had **more to do**.

Maintaining this balanced posture will be critical to our introduction.

So, as we answer these questions:

- What is our strategy for growth?
- What is our investor/shareholder value proposition?
- How will our performance be measured?
- How is our mission fulfilled through our business strategy?

**PROPRIETARY AND CONFIDENTIAL –
CONFIDENTIAL TREATMENT REQUESTED
BY FANNIE MAE**

Confidential - Internal Distribution

72

**Confidential Treatment
Requested By Fannie Mae**

FMSE 720773

The tone and manner will be:

- Understate, over deliver
- Continual *striving* for excellence (not just congratulating ourselves on achieving it)
- Well-grounded, focused
- Accepting of skepticism and listening to criticism

And the impression we leave:

- Focused intently on doing the job, meeting our goals, fulfilling our mission
- Business-to-business focused – not business-to-consumer focused
- Nimble, market driven
- Reliable, service-oriented, and value-producing

As this list implies, at the core of our message going forward is an understanding of what Fannie Mae can deliver to its many diverse stakeholders. This is the essence of classical “brand positioning.” Over the last year-and-a-half, beyond the listening tours, we have conducted formal research on the expectations of our stakeholders, especially our customers. What we learned is that their expectations did not always align with our message.

For much of the last 15 years, our positioning conflicted with our activities. Through annual reports, our charitable activities, television advertising, our speeches, and our relations with policy makers and the media, we positioned Fannie Mae as a consumer company. We sought to convey an impression that we served the American Homeowner, a consumer. While the romance implicit in that message is potent and should remain implicit in our mission, the fact is we are not a consumer company. While our mission is to bring global capital to address the housing needs of America, we do it by being a *business-to-business provider of financial services*. *We serve other businesses*. When we go after their customers, they cease to be our business partners, and become suspicious, hostile and un-partner-like.

Repositioning ourselves as a business-to-business company is part of our strategic plan, and our message should closely align with this strategy, both internally and externally.

Operationally, the reintroduction will take place in two phases. In the first phase, taking place over 200 days beginning this fall, investors, employees and the media will be the focus audience.

**PROPRIETARY AND CONFIDENTIAL –
CONFIDENTIAL TREATMENT REQUESTED
BY FANNIE MAE**

Confidential - Internal Distribution

73

**Confidential Treatment
Requested By Fannie Mae**

FMSE 720774

Reintroduction Timeline

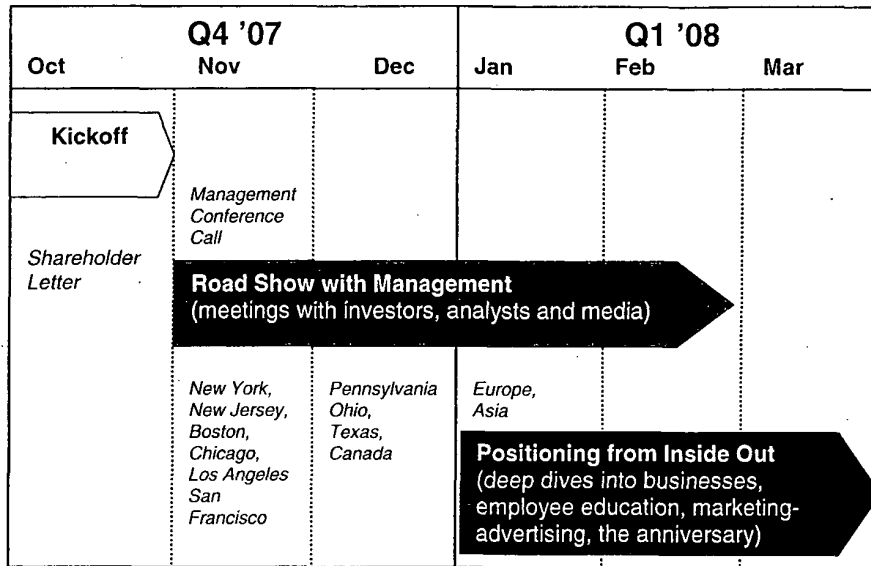

**PROPRIETARY AND CONFIDENTIAL -
CONFIDENTIAL TREATMENT REQUESTED
BY FANNIE MAE**

Confidential - Internal Distribution

74

**Confidential Treatment
Requested By Fannie Mae**

FMSE 720775

Phase One

Phase One of the reintroduction entails three aspects: A CEO letter to shareholders, a 200-day investor/media road show, and a employee engagement and education program.

The CEO shareholder letter will be posted electronically in October, and will be sent to all shareholders as part of the materials for the 2006 annual meeting. In addition, another 10,000 copies will be sent to a variety of other stakeholders. The letter will in a real sense kick off the 200-day campaign, framing the basic answers to these questions: Who are we? Where are we? How are our mission and our business linked? Where are we going?

Over the 200 days, senior management will conduct 100 meetings in 25 cities. The meetings will be formal investor conferences, one-on-one meetings with significant shareholders and partners, as well as editorial-board meetings with media organizations. The message and the presentation will be similar, no matter the venue or audience: our basic value proposition, our business and strategic goals, and how we are going to accomplish those goals. For investors, the objectives are to appeal to a broader base, ramp up our outreach, expand our disclosures, and articulate the strategy. For the media, the objective is to move beyond the "no comment" position we've often been forced to offer since 2004. The objective will be to return to orderly, deliberate and routine interactions with the press – including forms of "new" media as well as national, regional and local outlets.

The third part of Phase One will be the all-important campaign on the home front, a company-wide effort to infuse business-to-business positioning and values throughout Fannie Mae's employee base. We will do this by undertaking regular and measurable projects to increase employee education about the business as well as encouraging specific behaviors that build the brand proposition. The effort, parts of which have already been implemented, will involve everything from new-employee orientation to online training modules for existing employees.

Next year is Fannie Mae's 40th anniversary as a private company, and its 70th birthday. We will use the occasion not only to recognize the accomplishments of the past, but to set the stage for a new future for our organization.

Phase Two

The second phase is more wholesale in scope, involving broad initiatives to position the company with our customers and in the market place as nimble, responsive and business-oriented. Again, some of the initiatives are well underway. Single-Family has been the focus of our brand-building efforts so far, and is undertaking major initiatives in its customer-relationship-management, sales and marketing efforts.

Finally, Phase Two will include rollouts of new print advertising, and possibly a new logo and a new mission statement. Again, these efforts will adhere closely to our business-to-business positioning, focusing on one basic premise: We serve our partners in the housing finance system, and by doing so we create lasting value for shareholders and expand housing opportunities for all Americans.

**PROPRIETARY AND CONFIDENTIAL –
CONFIDENTIAL TREATMENT REQUESTED
BY FANNIE MAE**

Confidential - Internal Distribution

75

**Confidential Treatment
Requested By Fannie Mae**

FMSE 720776

Possible new logo . . .

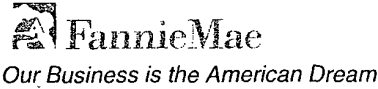

New Advertising with Business-to-Business Message . . .

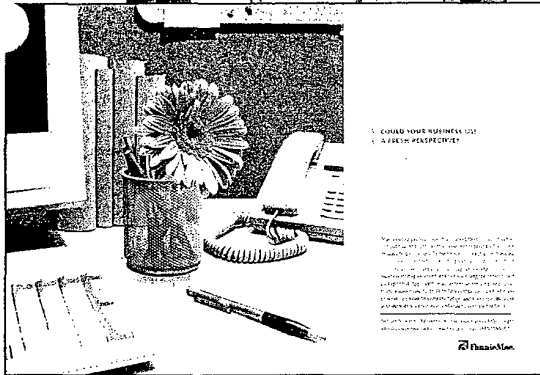

And a Possible New Mission Statement

Fannie Mae's Current Mission Statement . . .

At Fannie Mae, we are in the American Dream business. Our Mission is to tear down barriers, lower costs, and increase the opportunities for homeownership and affordable rental housing for all Americans. Because having a safe place to call home strengthens families, communities, and our nation as a whole.

And A Draft Mission Statement . . .

Fannie Mae exists to serve those who house America. Our job is to provide our customers and partners with the services, solutions and access to global capital they need to meet the ever-changing housing needs of our nation's communities. We strive to create lasting value for our shareholders and expand housing opportunities for all Americans.

**PROPRIETARY AND CONFIDENTIAL -
CONFIDENTIAL TREATMENT REQUESTED
BY FANNIE MAE**

Confidential - Internal Distribution

76

**Confidential Treatment
Requested By Fannie Mae**

FMSE 720777

Section VI Summary Points

- *Position as business-to-business*
- *Reintroduce consistent tone and manner*
- *Two-phased plan*
 - *200-day "blitz"*
 - *Ongoing return to normal*
 - *Examine re-branding*

Consistent alignment of strategy, metrics, message

**PROPRIETARY AND CONFIDENTIAL -
CONFIDENTIAL TREATMENT REQUESTED
BY FANNIE MAE**

Confidential - Internal Distribution

77

**Confidential Treatment
Requested By Fannie Mae**

FMSE 720778

Summary & Conclusion

**Confidential Treatment
Requested By Fannie Mae**

FMSE 720779

Summary and Conclusion

We developed this strategic business plan in a spirit of optimism. After spending the past two years rebuilding the company, we are on a sounder footing for the future. Meanwhile, our businesses, in fact, have performed solidly. Fannie Mae continued to play a key role in the U.S. housing finance system, raising and supplying billions of dollars in capital, helping lenders and housing partners serve the nation's housing needs, and providing value to shareholders.

But while our enterprise is in good shape, and still one of the most profitable companies in the world, we begin the next chapter of Fannie Mae with a new challenge – to seize new opportunities to compete, win, grow, thrive and serve our shareholders and housing in America. That is the goal of this Strategic Business Plan.

We started with the givens – a charter with great value, a growing but competitive market, some competitive advantages in our market, and a clear mission, purpose and vision.

Accepting these givens, we then made considered choices about our strategy, recognizing that having a charter is just the framework for our strategic options. But we began by imagining we were starting from scratch, and asking what direction we would take and what choices we would make.

We are making here a strategic choice to grow organically – doing the most with the market, businesses and competitive advantages we have to grow and add value. We believe of all the options, this is the most attractive to proposition to shareholders. Choosing this option also means deciding to stop and/or shed activities that have low value to shareholders and our mission. If there is something we're doing internally that we should stop or sell, we should do so. Accordingly, some of the choices – Community Business Centers, the Fannie Mae Foundation, the primacy of the MBS, and cost-cutting, to name a few – have been painful or contentious.

We have a distinct and important *raison d'être* – to be the most effective mover of global capital to U.S. housing.

We have a strategic path – to maximize the value of our three business segments within the framework of the charter, with the first priority being to protect the value of the MBS, our flagship, while serving the mission.

We have opportunities to broaden and deepen our reach within our market. Nearer term, we have a growth opportunity by taking more credit risk on balance sheet. Longer term, we have a growth opportunity by leveraging the brand and scale of Fannie Mae securitization business. Our mortgage portfolio continues to have strong value for the enterprise not just through fair value growth, but also as a support function to our other businesses. The portfolio's central strategy is to have the economics – not a pre-determined absolute number – drive the size. Costs also matter – we will drive a wedge between revenue growth and expenses; next year will start “the new normal” for Fannie Mae. Expenses will be down,

**PROPRIETARY AND CONFIDENTIAL –
CONFIDENTIAL TREATMENT REQUESTED
BY FANNIE MAE**

Confidential - Internal Distribution

78

**Confidential Treatment
Requested By Fannie Mae**

FMSE 720780

permanently; efficiencies will be up and increase year over year; and the numbers to measure performance will be clear internally and externally.

We will align our financial measures and metrics with how we manage the business, with three progressive drivers: Revenue growth; cost containment; and capital management. We will measure our credit guaranty businesses and report them on a GAAP basis; Capital Markets on a fair value basis; and any non-GAAP measures will be reconciled to GAAP, consistent with SEC rules for companies that run their business on something other than GAAP.

We start with the right attitude – we are not going back to the “velvet fist” of the past. I make no judgment about what may have been right at the time. But it is not what I feel is right going forward. We learned our lessons about hubris and humility; we embrace our position in the secondary mortgage market; and we recognize that in order to grow and thrive we must focus on service – and providing better service than our competitors in the secondary market. For us, humility is not just the right attitude; it is a strategic business imperative.

So, as we reintroduce the next Fannie Mae, expectations are high but our voice will be measured. You will see a tone shift from the past, from superlatives to facts; explicit mention of customers and partners; and letting our actions – and successes – speak for themselves.

We have many reasons to feel positive about the future. We are near closing a difficult chapter in our history, successfully and in better shape. Our business is growing, putting people into housing and making money for shareholders. We have over 2,000 customers nationwide that choose to do business with us every day. Our stock price is recovering. Our MBS is the most liquid in the market. Our debt securities are valued the world over. We are focused more on deeds than words, and delivering the numbers. We are clearing the legislative/legal/regulatory overhangs. Relationships with customers, partners, shareholders, stakeholders, regulators and Congress are as normal as they have ever been. And I believe we have one of the best sets of Directors, Managers and Associates not only in Fannie Mae’s history, but in Corporate America today.

Finally, we are optimistic and we are committed because we have chosen to affiliate ourselves with a business that has a soul ... our Mission. This is a blessing that is different from other companies that make loans, or manufacture equipment or sell soft drinks. We have all seen what Fannie Mae can do when we get it right: families realize their dreams, communities are transformed, and economies are boosted. We have seen Fannie Mae get it right in Los Angeles, in LeDroit Park in Washington, DC, on the Texas border, on the Gulf Coast, and most likely in the towns where we all grew up. We all share a common wave of pride, solidarity and hope when someone, learning of our role at this company, says, “Fannie Mae made it possible for me to own my home.”

Desiree George of New Orleans was visiting her sisters in Texas when Hurricane Katrina destroyed her home. She decided to stay in Texas, and learned that Fannie Mae was offering homes from our inventory for people in her situation. She’s been in one of those

**PROPRIETARY AND CONFIDENTIAL -
CONFIDENTIAL TREATMENT REQUESTED
BY FANNIE MAE**

Confidential - Internal Distribution

79

**Confidential Treatment
Requested By Fannie Mae**

FMSE 720781

homes since December 2005, and now hopes to buy it. She said, simply, "Fannie Mae came through at the worst time of my life."

We have work to do.

**PROPRIETARY AND CONFIDENTIAL -
CONFIDENTIAL TREATMENT REQUESTED
BY FANNIE MAE**

Confidential - Internal Distribution

80

**Confidential Treatment
Requested By Fannie Mae**

FMSE 720782

Appendix: Where We've Been -
A Brief History

Confidential Treatment
Requested By Fannie Mae

FMSE 720783

Appendix: Where We Have Been – A Brief History

For those not familiar with Fannie Mae's history (and/or mythology!), the following is a brief rundown of our 70 years since our founding to put our current strategic plan in a broader context. Another way of putting that: To understand where we need to go, we have to understand how we got here. Looking back, our history unfolds as an ongoing story of change and progress, each chapter driven by pivotal events and strategic choices.

- Chapter 1: The Birth. As part of the New Deal, President Franklin Roosevelt established the Federal National Mortgage Association in 1938 to buy and hold FHA (and then Veterans Administration) government-backed mortgages to boost homeownership among middle-class Americans. In 1954, under a new charter, FNMA became a "mixed-ownership" corporation owned partly by private shareholders. When the Department of Housing and Urban Development (HUD) was created in 1965, it assumed supervision of FNMA.



- Chapter 2: The Rebirth. In 1968, President Lyndon Johnson signed legislation chartering FNMA as a private, shareholder-owned company to move the agency off the government books and help balance the federal budget.



In 1970, as we completed our transition to a private company, President Richard Nixon signed legislation authorizing us to purchase conventional mortgages, and our common stock began trading on the New York Stock Exchange (NYSE). Also in 1970, Congress chartered Freddie Mac. Fannie Mae changed its loan purchase method from posting predetermined prices to the Free Market System commitment auctions.

**PROPRIETARY AND CONFIDENTIAL –
CONFIDENTIAL TREATMENT REQUESTED
BY FANNIE MAE**

Confidential - Internal Distribution

81

**Confidential Treatment
Requested By Fannie Mae**

FMSE 720784

- **Chapter 3: Back from the Brink.** In 1981, a surge in interest rates sent Fannie Mae's mortgage portfolio – primarily long-term, fixed-rate mortgages funded by short-term paper – dangerously out of balance, causing the company at one point to lose over a million dollars a day, and to post its first annual loss. We made strategic decisions to launch a mortgage-backed securities (MBS) business, and began purchasing adjustable-rate mortgages, second mortgages and conventional multifamily loans. We entered the foreign capital markets – broadening our source of funding – closing the chapter with turnaround and growth for the company.
- **Chapter 4: Rise to Dominance.** As Fannie Mae stock joined the S&P 500 and our MBS became the market leader, we came under a new regulator – the Office of Federal Housing Enterprise Oversight (OFHEO) -- new capital rules and new affordable housing goals. We made strategic decisions to launch automated underwriting technology and establish local partnership offices nationwide. We set up a separate foundation for the purpose of “consumer education,” and in 1994 launched a Trillion Dollar Commitment to affordable housing. Our book of business reached \$1 trillion and stock price reached \$80; we reported double-digit “core” earnings growth for 14 consecutive years. In 1999, management established a goal to double earnings per share from \$3.23 to \$6.46 in five years. Commercial banks, large financial institutions, mortgage insurers (and a few customers) contributed millions of dollars to fund a Washington-based, bipartisan lobbying and public relations organization called “FM Watch” to raise questions about our size and practices. In 2000, after achieving our \$1 trillion affordable housing commitment almost a year ahead of schedule, we launched a ten-year, \$2 trillion American

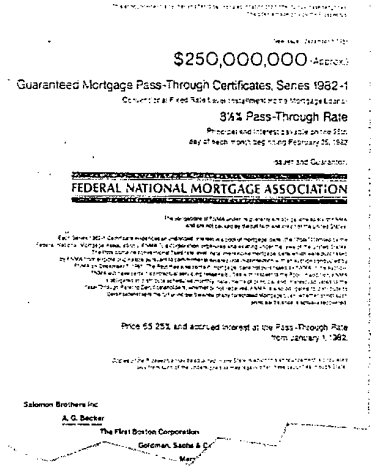

Fannie Mae to Fund \$2 Trillion of New Mortgages

By Patrick Schafer
Staff Reporter of THE WALL STREET JOURNAL

Fannie Mae, the government-chartered corporation that provides capital to the mortgage market, unveiled a program it says will boost homeownership rates among lower-income families while helping to revitalize needy neighborhoods.

The plan calls for Fannie Mae to underwrite 27 trillion of new mortgages during the next 10 years, for minorities, young families, woman-headed families, inventors and others whose homeownership rates lag behind the general population. That target is an extension of a similar goal set in 1974 in which the corporation pledged \$1 trillion to help low-income families attain homeownership.

The "American Dream Commitment" includes a program to finance more than \$15 billion in affordable rental housing, as well as the expansion of an existing investment fund it uses to build and remodel homes, buy land and make other infrastructure improvements in needy communities. Fannie Mae will add \$1 billion to that program, which has spent \$29 million in 31 communities since its inception in 1986. The announcement was greeted with skepticism by some critics of Fannie Mae, who question whether the new loans targeted at lower-income families will be profitable.

Mae's underwriting system and expects to release its findings later in the year. Fannie Mae says it has loosened underwriting requirements since 1994 in order to finance loans it otherwise would have rejected. For example, the company has lowered the minimum down payment for home's total cost; before 1994, it typically only took for 20% down.

Two weeks ago, Fannie Mae reported a 25% increase in its earnings per share.

Dream Commitment, including a "Mortgage Consumers Bill of Rights." We relinquished our charter exemption to the 1934 Securities Act and registered our common stock with the Securities and Exchange Commission.

PROPRIETARY AND CONFIDENTIAL - CONFIDENTIAL TREATMENT REQUESTED BY FANNIE MAE

Confidential - Internal Distribution

82

Confidential Treatment Requested By Fannie Mae

FMSE 720785

- Chapter 5: Fall to Earth. In 2001, Fannie Mae was cited among 11 companies in a best-selling business book by Jim Collins, Good to Great. In 2004, having reached our ten-year American Dream Commitment in four years following record growth in the mortgage market, we launched our American Dream Commitment 3.0 with over 60 specific housing initiatives. Later that year, OFHEO commenced a special review of our accounting policies in response to accounting issues at Freddie Mac.

Report of the Special Examination of
Fannie Mae



May 2006

In September, OFHEO issued an interim report finding that our accounting policies, controls, corporate governance and a range of other company practices and operations were seriously deficient. We disagreed and appealed to the SEC. Media reports began using the term “scandal” and comparing Fannie Mae to Enron, WorldCom and Tyco. In December 2004, the SEC ruled that we violated generally accepted accounting principles, notably in our treatment of hedge accounting, requiring one of the largest financial restatements in U.S. corporate history. We were found severely undercapitalized. Senior management – including the CEO, CFO and internal auditor – departed and the company terminated its longtime independent audit firm.

- Chapter 6: Dark Days and Recovery. The company began 2005 with the task of rebuilding from the ground up: regulatory capital, including a 30 percent surplus; the executive team; financial, accounting and audit organizations; accounting policies, practices, systems and controls; relationships with regulators, Congress, customers, shareholders and stakeholders; compliance and other major policies; technology infrastructure; company culture and external tone and manner. We were under investigation by the SEC and the Justice Department, and being sued by shareholders. In 2006 the Board issued its Paul, Weiss internal investigation report finding that our accounting practices were not consistent with GAAP, accounting systems were “grossly inadequate,” and the “corporate culture suffered from an attitude of arrogance (both internally and externally) and an absence of cross-enterprise teamwork (with a ‘siloing’ of information), and discouraged dissenting views, criticism, and bad news.” OFHEO issued its final special examination report of the period 1998-2004 finding that the image the company had promoted as one of the lowest-risk financial institutions in the world and as best in class in terms of risk management, financial reporting, internal controls and corporate governance was “false,” and that we had overstated reported income and capital by over \$10 billion. We reached settlements with the SEC and OFHEO, including an agreement to cap the portfolio, and paid \$400 million in fines. The Justice Department discontinued its investigation into our accounting practices and policies.

**PROPRIETARY AND CONFIDENTIAL -
CONFIDENTIAL TREATMENT REQUESTED
BY FANNIE MAE**

Confidential - Internal Distribution

83

**Confidential Treatment
Requested By Fannie Mae**

FMSE 720786

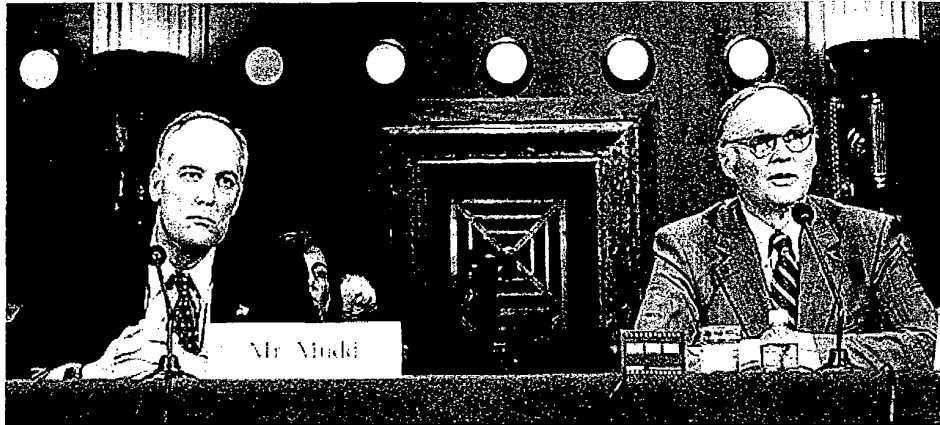

We testified before Congress several times. Fannie Mae survived the threat of NYSE delisting. Since 2005, 80 percent of senior management changed – half are new to the company, and half are in materially new roles. The company also established compliance, ethics, risk and various oversight functions, and continued to be the subject of various legal matters. The corporation announced the closing of the Fannie Mae Foundation, and the end of former lobbying practices.

Business-wise, we stepped back from the surge in “layered-risk” subprime mortgages flooding the market, and gave up market share to private label competitors, but kept the businesses operating as we began restructuring and realigning them to be a more cohesive, efficient and market-responsive One Fannie Mae. Finally, in November 2006 we filed our 2004 10-K with our completed restatement and absorbed a \$6.3 billion hit to previous retained earnings, filed our 2005 10-K in May 2007, and set a new timeline to file our 2006 10-K (3Q/07), hold our first shareholder meeting in three years (12/07), and return to timely filing (2/08).

**PROPRIETARY AND CONFIDENTIAL -
CONFIDENTIAL TREATMENT REQUESTED
BY FANNIE MAE**

Confidential - Internal Distribution

84

**Confidential Treatment
Requested By Fannie Mae**

FMSE 720787